

CHAPE FEMELLE A SOUDER
WELDABLE FORK

CFS

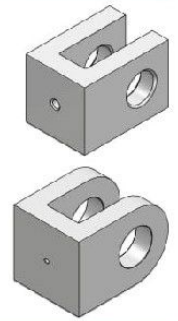
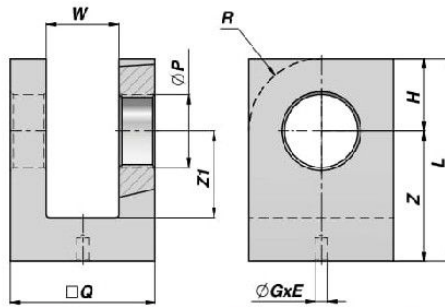

Code Code	ØP	ØQ	W	Z	Z1	H	L	R	ØGxE	kg	Boîte Box	NEW!	Pcs Pcs
CFS0000016	16.20	35	16	34	24	16	50	-	ø 4.25 x 6	0,27	Z50CFS1600000		50
CFS0000020	20.25	40	20	40	30	20	60	-	ø 4.25 x 6	0,38	Z50CFS2000000		50
CFS0000025	25.25	50	25	45	30	25	70	-	ø 4.25 x 8	0,71	Z25CFS2500000		25
CFS0000030	30.25	60	30	50	35	30	80	30	ø 4.25 x 8	1,10	Z20CFS3000000		20
CFS0000035	35.25	70	35	55	40	35	90	35	ø 4.25 x 8	1,60	Z10CFS3500000		10
CFS0000040	40.25	80	40	70	50	40	110	40	ø 4.25 x10	2,70	Z05CFS4000000		5
CFS0000050	50.50	100	50	95	60	50	145	50	ø 6.25 x12	5,86			
CFS0000060	60.50	110	60	105	65	55	160	55	ø 6.25 x12	7,34			

MATERIEL : ACIER S235JR (Fe360/Fe360B)
MATERIAL : STEEL S235JR (Fe360/Fe360B)

CHAPE FEMELLE TARAUEE
THREADED FORK

CFF

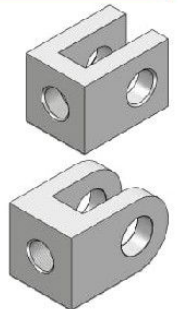
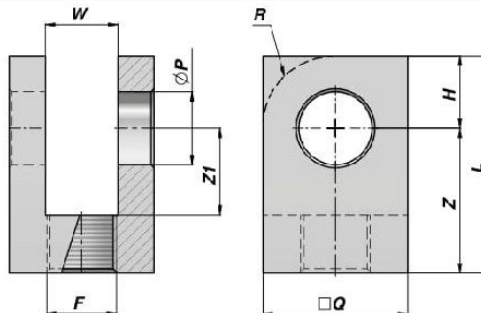

Code Code	ØP	ØQ	W	Z	Z1	H	L	R	F	kg	Boîte Box	NEW!	Pcs Pcs
CFF0161615	16.20	35	16	39	24	16	55	-	M16x1.5	0,30	Z50CFF0161615		50
CFF0202015	20.25	40	20	45	30	20	65	-	M20x1.5	0,40	Z50CFF0202015		50
CFF0252420	25.25	50	25	50	30	25	75	-	M24x2	0,75	Z25CFF0252420		25
CFF0303020	30.25	60	30	65	35	30	95	30	M30x2	1,46	Z10CFF0303020		10
CFF0353320	35.25	70	35	75	40	35	110	35	M33x2	1,67	Z10CFF0353320		10
CFF0403320	40.25	80	40	85	50	40	125	40	M33x2	3,20	Z05CFF0403320		5
CFF0504530	50.50	100	50	100	60	50	150	50	M45x3	5,82			
CFF0605640	60.50	110	60	110	65	55	165	55	M56x4	7,07			

MATERIEL : ACIER S235JR (Fe360/Fe360B)
MATERIAL : STEEL S235JR (Fe360/Fe360B)