

MULTIPLICATEUR POUR POMPE GR.3
P.T.O. GEAR BOX FOR GR.3 PUMP

GBML52

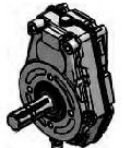
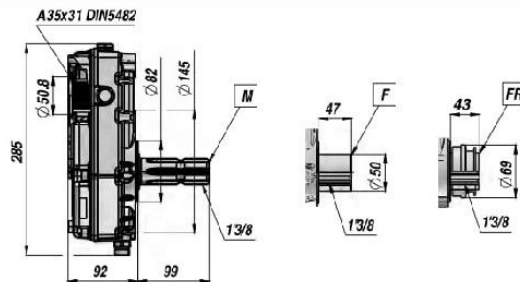

Code Code	Type Type	Arbre - Shaft		Rapport Ratio	kg
		Entrée - Input	Sortie - Output		
BM70001030	GBML52 - M - 1 / 2.5	Mâle Male 1"3/8 SAE J 1170	Femelle Female A 35x31 DIN 5482	2.6	7,90
BM70001040	GBML52 - M - 1 / 3.0			3.0	7,90
BM70001050	GBML52 - M - 1 / 3.4			3.4	7,90
BM70001060	GBML52 - M - 1 / 3.8			3.8	9,20
BM70002015	GBML52 - F - 1 / 1.5	Femelle Female 1"3/8 SAE J 1170	Femelle Female A 35x31 DIN 5482	1.5	7,10
BM70002020	GBML52 - F - 1 / 2.0			2.0	7,10
BM70002030	GBML52 - F - 1 / 2.5			2.6	7,10
BM70002040	GBML52 - F - 1 / 3.0			3.0	7,10
BM70002050	GBML52 - F - 1 / 3.4			3.4	7,10
BM70002060	GBML52 - F - 1 / 3.8			3.8	8,40
BM70004040	GBML52 - FR - 1 / 3.0	Femelle FR Female FR 1"3/8 SAE J 1170	Femelle Female A 35x31 DIN 5482	3.0	7,30
BM70004060	GBML52 - FR - 1 / 3.8			3.8	8,60

MATERIEL CORPS : ALUMINIUM
BODY MATERIAL : ALUMINIUM

- TAVOLA RICAMBI MOLTIPLICATORE POMPE Gr. 3
- TABLEAU DES PIÈCES DÉTACHÉES DU MULTIPLICATEUR POUR POMPE Gr. 3
- OVER-GEAR SPARE PARTS TABLEAU PUMPS Gr. 3
- ERSATZTEILLISTE ÜBERSETZUNGSGETRIEBE Gr. 3

SERIE: 71000

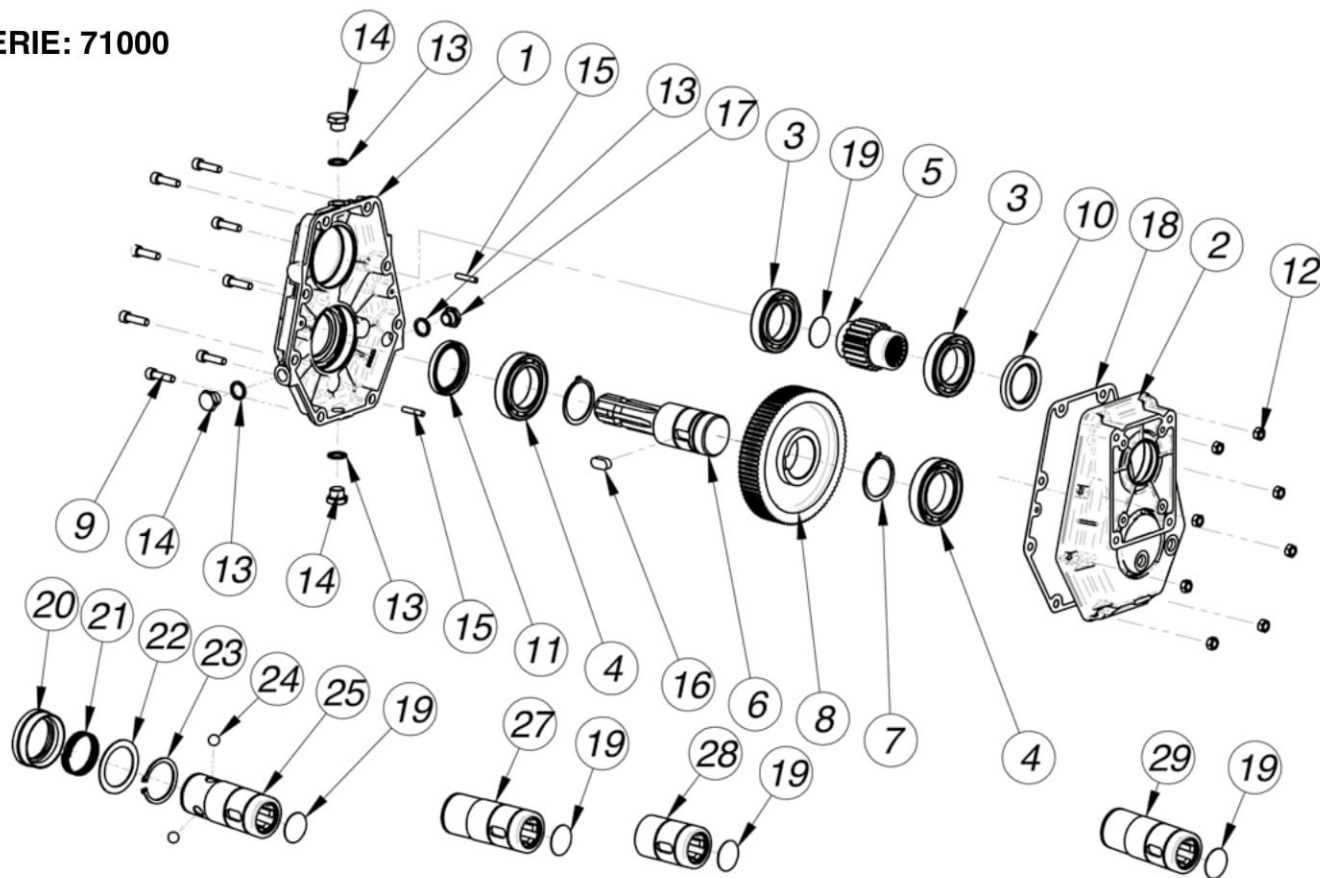

Pos.	DENOMINAZIONE	DENOMINATION	DESCRIPTION	BEZEICHNUNG	Q.TA'
1	Scatola	Carcasse	Housing	Gubeisen	1
2	Coperchio	Couvercle	Cover	Deckel	1
3	Cuscinetto tipo 6009	Palier 6009	Bearing 6009	Kugellager Type 6009	2
4	Cuscinetto tipo 6010	Palier 6010	Bearing 6010	Kugellager Type 6010	2
5	Pignone	Pignon	Pinion gear	Ritzel	1
6	Albero presa di forza maschio 1"3/8 Z6	Arbre prise de force mâle 1"3/8 Z6	Female P.T.O. shaft 1"3/8 Z6	Antriebswelle mit Innenverkeilung 1"3/8 Z6	1
7	Anello seeger d.50	Circlip d.50	Snap ring d.50	Seegerring, Durchm. 50	2
8	Corona	Couronne	Ring gear	Zahnkranz	1
9	Vite V.T.C.E.I M8x30	Vis V.T.C.E.I M8x30	Socket capscrew M8x30	Zylinderkopfschraube mit Innensechskant M8x30	8
10	Anello di tenuta 45x65x8	Bague d'étanchéité 45x65x8	Sealing ring 45x65x8	Dichtring, Durchm. 45x65x8	1
11	Anello di tenuta 50x65x8	Bague d'étanchéité 50x65x8	Sealing ring 50x65x8	Dichtring, Durchm. 50x65x8	1
12	Dado M8	Ecrou M8	Nut M8	Mutter M8	8
13	Guarnizione	Joint	Gasket	Dichtung	4
14	Tappo scarico olio 3/8"	Bouchon vindage huile 3/8"	Oil drain plug 3/8"	Olablabschraube 3/8"	3
15	Spina d.6	Goupille d.6	Peg d.6	Stift Durchm. 6	2
16	Chiavetta 12x25	Clavette 12x25	Key 12x25	Keil 12x25	1
17	Tappo livello olio 3/8"	Bouchon niveau huile 3/8"	Oil drain plug 3/8"	Olstandschrabe 3/8"	1
18	Guarnizione	Joint	Gasket	Dichtung	1
19	Coperchietto DIN 470 D.37	Petit couvercle D.37 DIN 470	Cap DIN 470 D.37	Deckel DIN 470 , D.37	1
20	Anello porta molla	Bague porte-ressot	Spring ring	Federhülter	1
21	Molla	Ressot	Spring	Feder	1
22	Anello	Bague	Ring	Ring	1
23	Anello seeger UNI 7435 - 50	Circlip UNI 7435 - 50	Snap ring UNI 7435 - 50	Seegerring UNI 7435 - 50	1
24	Sfera d.13	Bille d.13	Ball d.13	Kugel Durchm 13	1
25	Albero presa di forza femmina 1" 3/8" Z6 attacco rapido	Arbre prise de force femelle 1"3/8" Z6 attelage rapide	Female P.T.O. shaft 1"3/8" Z6, Quick fitting	Antriebsw.m. Innenverkeilung 1" 3/8" Z6 , mit Schnellkupplung	1
27	Albero presa di forza femmina lunga 1" 3/8" Z6	Arbre prise de force femelle long 1"3/8" Z6	Female P.T.O. shaft 1"3/8" Z6 long	Antriebsw.m. Innenverkeilung 1" 3/8" Z6 , lang	1
28	Albero presa di forza femmina corta 1" 3/8" Z6	Arbre prise de force femelle long 1"3/8" Z6	Female P.T.O. shaft 1"3/8" Z6 long	Antriebsw.m. Innenverkeilung 1" 3/8" Z6 , lang	1
29	Albero presa di forza femmina lunga Z21 16/32" DP	Arbre prise de force femelle long Z21 16/32" DP	Female P.T.O. shaft Z21 16/32" DP long	Antriebsw.m. Innenverkeilung Z21 16/32" DP , lang	1

- **MOLTIPLICATORE POMPE Gr. 3**
- **MOLTIPLICATEUR POUR POMPES Gr. 3**
- **PUMP OVER-GEAR Gr. 3**
- **ÜBERSETZUNGSGETRIEBE FÜR PUMPEN Gr. 3**

SERIE: 71000

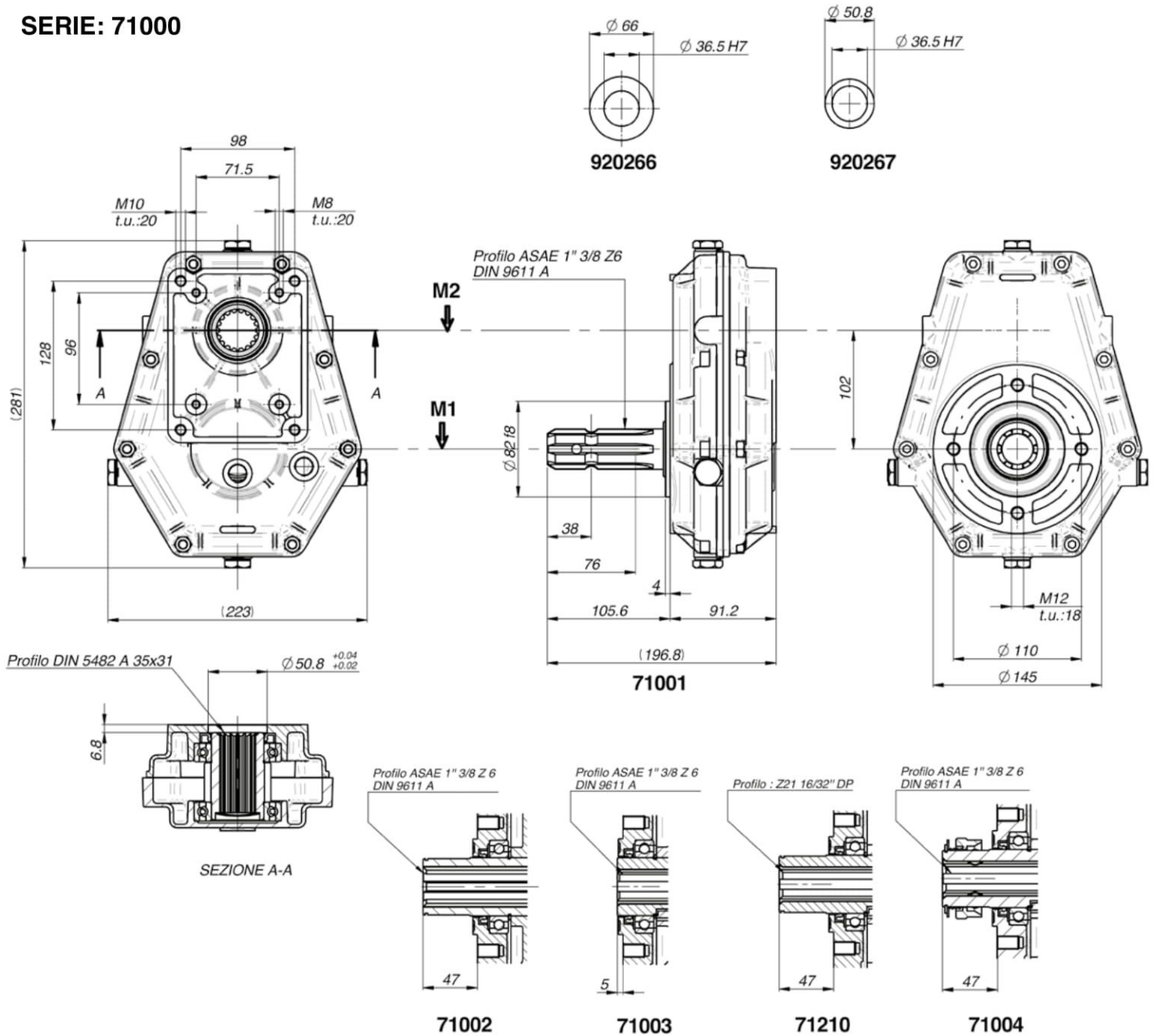

Livello max olio: it 0,350

M1 da Nm	M2 da Nm	N. 1 giri/1' tours/1' R.P.M U/min	N. 2 giri/1' tours/1' R.P.M U/min	I N.1/N.2	POTENZA Kw	G Kg
31	31	540	540	1	20	8,4
38	26	540	810	1,5	20	8,4
43	21	540	1080	2,2	20	8,4
46	18	540	1408	2,5	20	8,4
49	16	540	1620	3	20	8,4
46	13	540	1836	3,5	20	8,4
43,7	11,5	540	2057	3,8	20	8,4

- FLANGIE PER MOLTIPLICATORI SERIE: 71000
- FLANGE POUR MULTIPLIEUR SERIES 71000
 - BRYDE FOR OVER-GEAR SERIE: 71000
- FLANSCH FÜR ÜBERSETZUNGSGETRIEBE SERIE: 71000

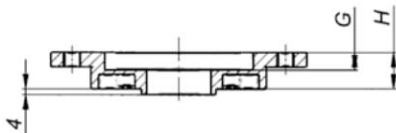
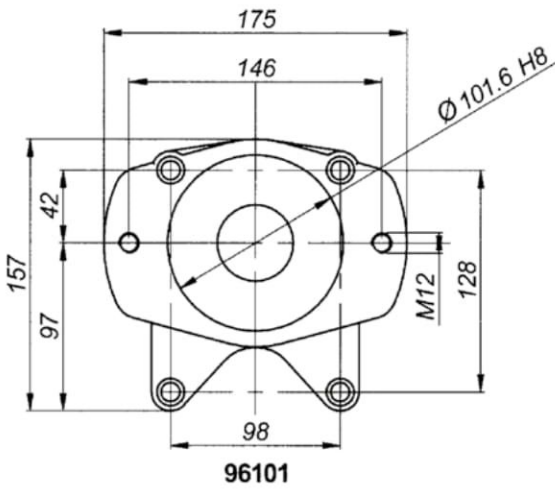
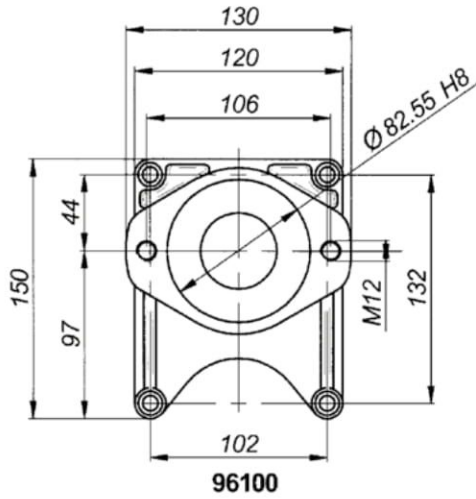

	FLANGIA: TIPO, BRIDE: TYPE FLANGE: TYPE, FLANSCHTYPE	
	SAE A Gr. 3	SAE B Gr. 3
Code	96100	96101
G	10	12
H	16	24

- TAVOLA RICAMBI MOLTIPLICATORE CON ALBERO PASSANTE POMPE Gr. 3
- TABLEAU DE PIÉCES DÉTACHÉES DU MOLTIPLICATEUR AVEC ARBRE PASSANT POUR POMPES GR. 3
- SPARE PARTS TABLE OVER-GEAR WITH THROUGH-SHAFT PUMP GROUP 3
- ERSATZTEILLISTE ÜBERSETZUNGSGETRIEBE MIT DURCHGEHENDER ANTRIEBSWELLE GR 3

SERIE: 70000

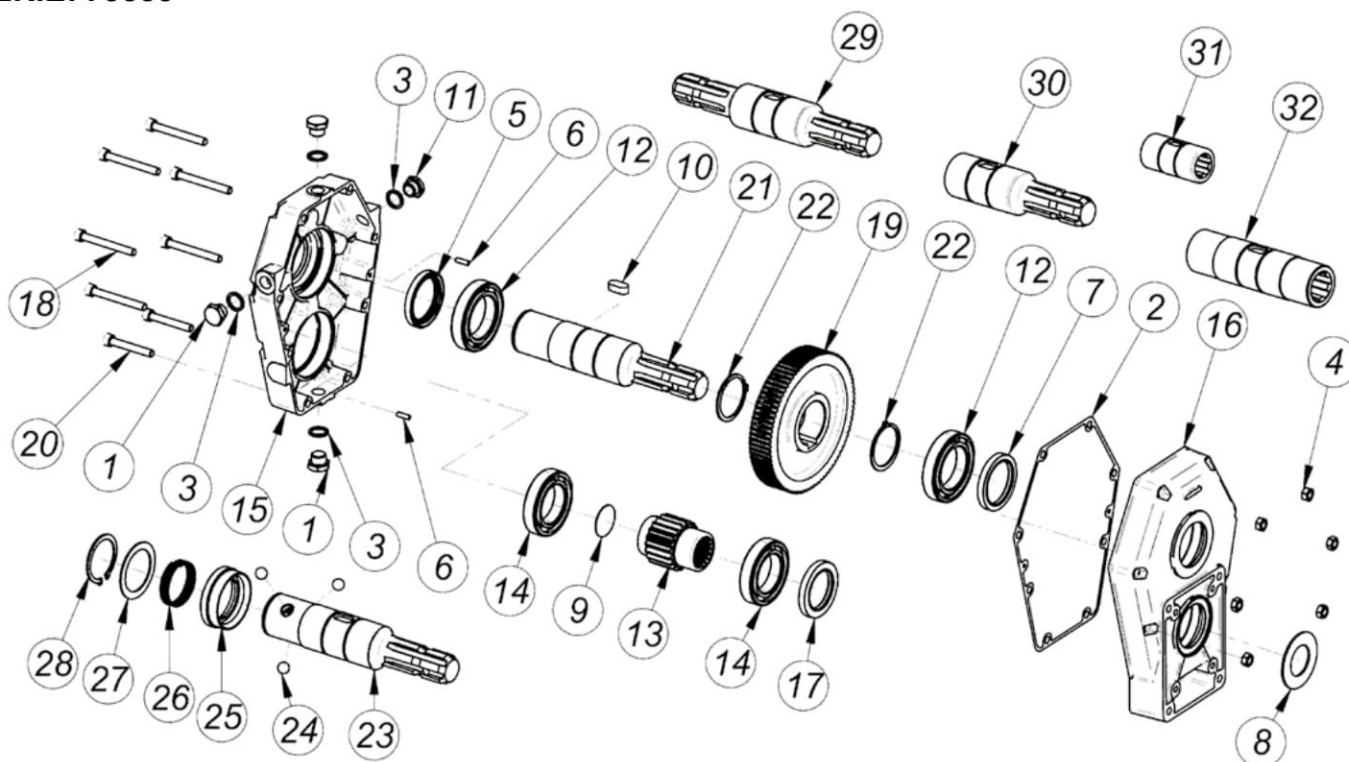

Pos.	DENOMINAZIONE	DENOMINATION	DESCRIPTION	BEZEICHNUNG	Q. TA'
1	Tappo scarico olio 3/8"	Bouchon vindage huile 3/8"	Oil drain plug 3/8"	Olablabschraube 3/8"	3
2	Guarnizione	Joint	Gasket	Dichtung	1
3	Guarnizione	Jiont	Gasket	Dichtung	4
4	Dado M8	Ecrou M8	Nut M8	Mutter M8	6
5	Anello di tenuta 50x65x8	Bague d'EtanchÉitÉ 50x65x8	Sealing ring 50x65x8	Dichtring, Durchm. 50x65x8	1
6	Spina UNI 8751 5x16	Goupille UNI 8751 D.5x16	Peg UNI 8751 5x16	Stift durchm UNI 8751 5x16	2
7	Anello di tenuta 50x65x8	Bague d'EtanchÉitÉ 50x65x8	Sealing ring 50x65x8	Dichtring, Durchm. 50x65x8	1
8	Anello di centraggio per pompa Gr. 2	Bague de centrage pour pompe Gr.2	Centering ring for pump group 2	Zentrierring für pumpe Gr 2	1
9	Coperchietto DIN 470 D.37	Petit couvercle D.37 DIN 470	Cap DIN 470 D.37	Deckel DIN 470 , D.37	1
10	Chiavetta 12x25	Clavette 12x25	Key 12x25	Keil 12x25	1
11	Tappo livello olio 3/8"	Bouchon niveau huile 3/8"	Oil drain plug 3/8"	Olstandschrabe 3/8"	1
12	Cuscinetto tipo 6010	Palier 6010	Bearing 6010	Kugellager Type 6010	2
13	Pignone	Pignon	Pinion gear	Ritzel	1
14	Cuscinetto 6009	Palier 6009	Bearing 6009	Kugellager Type 6009	2
15	Scatola	Carcasse	Housing	Gehäuse	1
16	Coperchio	Couvercle	Cover	Deckel	1
17	Anello di tenuta 45x65x8	Bague d'EtanchÉitÉ 45x65x8	Sealing ring 45x65x8	Dichtring, Durchm. 45x65x8	1
18	Vite T.C.E.I. M8x70	Vis T.C.H.C. M8x70	Socket capscrew M8x70	Zylinderkopfschraube mit innensechskant M8x70	6
19	Corona	Couronne	Ring gear	Zahnkranz	1
20	Vite T.C.E.I. M8x55	Vis T.C.H.C M8x55	Socket capscrew M8x55	Zylinderkopfschraube mit Innensechskant M8x55	2
21	Albero presa di forza femmina-maschio 1" 3/8" Z6	Arbre prise de force femelle-Male 1"3/8" Z6	Female-Male P.T.O. shaft 1"3/8" Z6	Antriebsw.m. Innenverkeilung-Aussenverkeilung 1" 3/8" Z6	1
22	Anello seeger d.50	Circlip d.50	Snap ring d.50	Seegerring, Durchm. 50	2
23	Albero presa di forza Femmina- maschio attacco rapido 1" 3/8" Z6	Arbre prise de force Female-Male attelage rapide 1" 3/8" Z6	Female-Male P.T.O. - Quick fitting shaft 1" 3/8" Z6	Antriebsw.m. Innenverkeilung , mit schnellkupplung 1" 3/8" Z6	1
24	Sfera	Bille	Ball	Kugel	3
25	Anello porta molla	Bague porte-ressot	Spring ring	Federhaltering	1
26	Molla	Ressort	Spring	Feder	1
27	Anello	Bague	Ring	Ring	1
28	Anello seeger UNI 7435 - 50	Circlip UNI 7435 - 50	Snap ring UNI 7435 - 50	Seegerring UNI 7435 - 50	1
29	Albero presa di forza maschio-maschio 1" 3/8" Z6	Arbre prise de force Male-Male 1"3/8" Z6	Male-Male P.T.O. shaft 1"3/8" Z6	Antriebsw.m. Aussenverkeilung-Aussenverkeilung 1" 3/8" Z6	1
30	Albero presa di forza femmina-maschio 1" 3/8" Z6 corta	Arbre prise de force femelle-Male 1"3/8" Z6 court	Female-Male P.T.O. shaft 1"3/8" Z6 schort	Antriebsw.m. Innenverkeilung-Aussenverkeilung 1" 3/8" Z6 kurz	1
31	Albero presa di forza femmina corta 1" 3/8" Z6	Arbre prise de force femelle court 1"3/8" Z6	Female P.T.O. shaft 1"3/8" Z6 schort	Antriebsw.m. Innenverkeilung 1" 3/8" Z6 kurz	1
32	Albero presa di forza femmina 1" 3/8" Z6	Arbre prise de force femelle 1"3/8" Z6	Female P.T.O. shaft 1"3/8" Z6	Antriebsw.m. Innenverkeilung 1" 3/8" Z6	1

- **MOLTIPLICATORE CON ALBERO PASSANTE POMPE Gr. 3**
- **MOLTIPLICATEUR AVEC ARBRE PASSANT POUR POMPES Gr. 3**
- **OVER-GEAR WITH THROUGH-SHAFT PUMPS Gr. 3**
- **ÜBERSETZUNGSGETRIEBE MIT DURCHGEHENDER ANTRIEBSWELLE FÜR PUMPEN GR 3**

SERIE: 70000

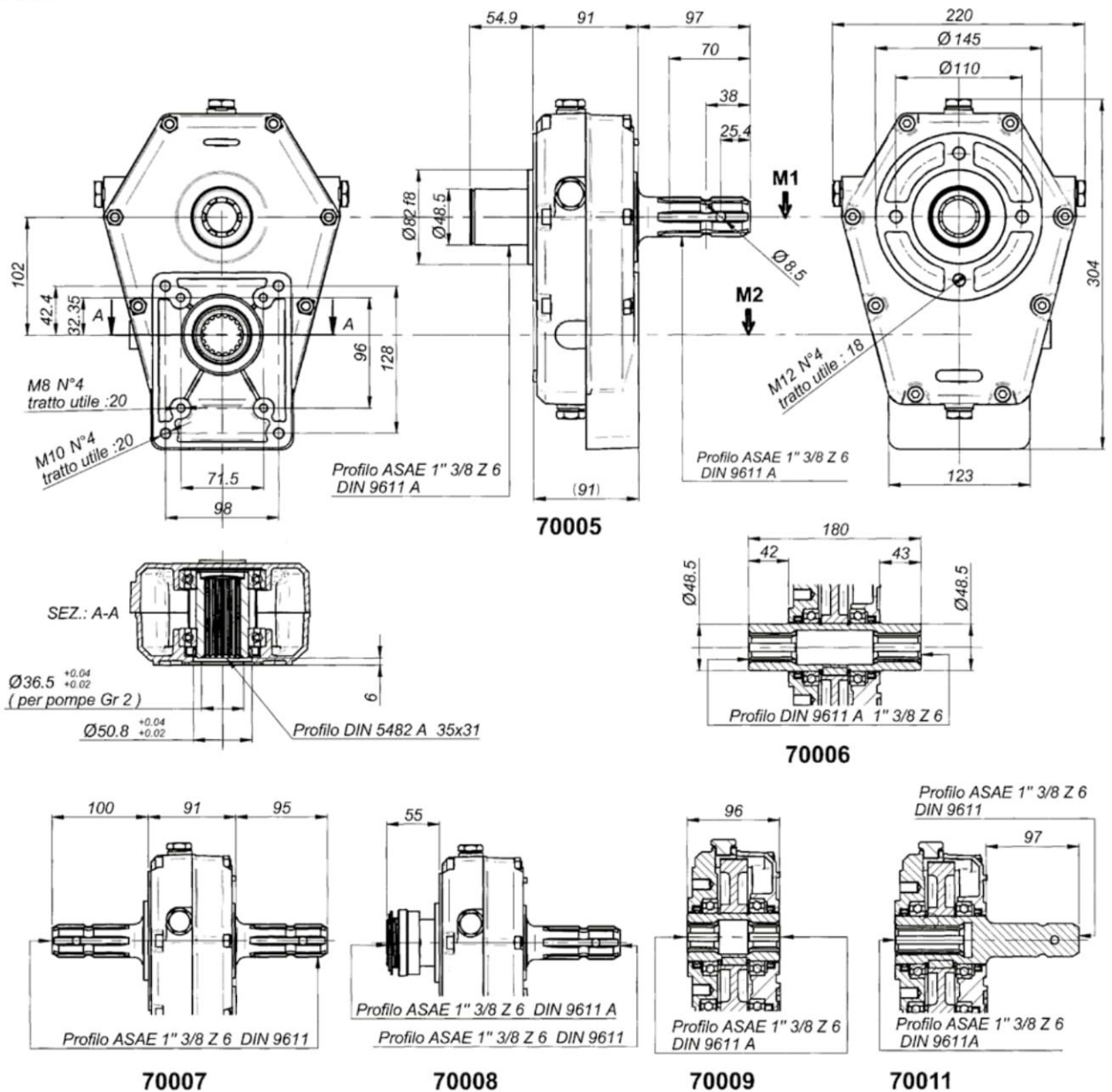

Livello max olio: it 0,350

M1 da Nm	M2 da Nm	N. 1 giri/1' tours/1' R.P.M U/min	N. 2 giri/1' tours/1' R.P.M U/min	I N.1/N.2	POTENZA Kw	G Kg
31	31	540	540	1	20	9,5
38	26	540	810	1,5	20	9,5
43	21	540	1080	2	20	9,5
46	18	540	1408	2,5	20	9,5
49	16	540	1620	3	20	9,5
46	13	540	1836	3,5	20	9,5
43,7	11,5	540	2057	3,8	20	9,5