

**DIVISEUR DE DEBIT TYPE STANDARD**  
 GEAR FLOW DIVIDER STANDARD TYPE  
 DIVISOR DE FLUJO TIPO ESTANDAR

**RV2D**

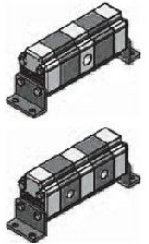
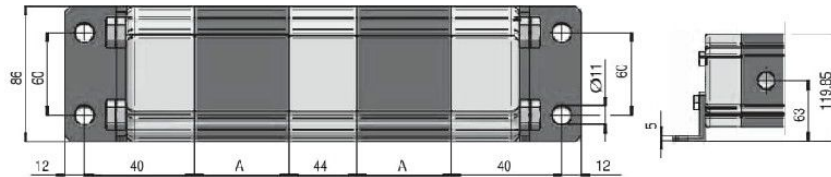

**DIVISEUR DE DEBIT AVEC LIMITEUR DE PRESSION PAR ELEMENT**  
 GEAR FLOW DIVIDER WITH RELIEF VALVE ON EACH ELEMENT  
 DIVISOR DE FLUJO CON VALVULA LIMITADORA DE PRESION EN CADA ELEMENTO

**RV2V**

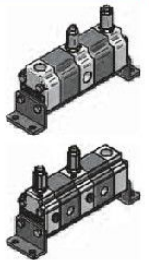
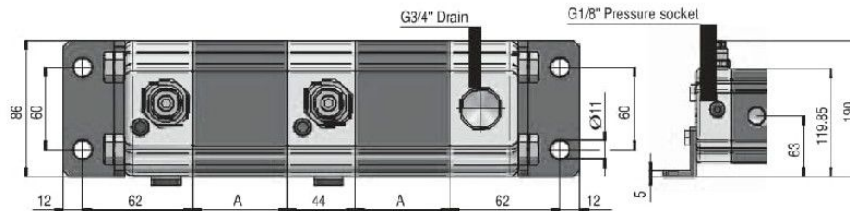

Type Type Tipo	cm <sup>3</sup> /tr cm <sup>3</sup> /rev cm <sup>3</sup> /giro	Q l/min per element			P MAX bar	A	IN BSP	OUT BSP	kg
		Min.	Optimal	Max.					
RV 2 - (D-V) 4	4,0	4,8	7,6	10	210	47	3/4"	1/2"	~2,20
RV 2 - (D-V) 6	6,0	7,2	10,8	15	210	50	3/4"	1/2"	~2,30
RV 2 - (D-V) 9	9,0	10,8	15,1	22,5	210	54	3/4"	1/2"	~2,40
RV 2 - (D-V) 11	11,0	13,2	19,4	27,5	210	58	3/4"	1/2"	~2,50
RV 2 - (D-V) 14	14,0	16,8	25,9	35	200	64	3/4"	1/2"	~2,70
RV 2 - (D-V) 17	17,0	20,4	30,2	42,5	200	68	3/4"	1/2"	~2,80
RV 2 - (D-V) 19	19,0	22,8	34,6	47,5	190	72	3/4"	1/2"	~2,90
RV 2 - (D-V) 22	22,0	26,4	41,0	55	180	78	3/4"	1/2"	~3,05
RV 2 - (D-V) 26	26,0	31,2	45,4	65	160	82	1"	3/4"	~3,15
RV 2 - (D-V) 30	30,0	36,0	54,0	75	160	90	1"	3/4"	~3,40
RV 2 - (D-V) 34	34,0	40,8	61,6	85	140	97	1"	3/4"	~3,60
RV 2 - (D-V) 40	40,0	48,0	71,3	100	130	106	1"	3/4"	~3,80

Les données du tableau se réfèrent à chaque élément.  
 The data of the table refer to a single element.  
 Los datos del cuadro se refieren a cada elemento.

A flow divider is made up of two or more modular elements (sections) with gears mechanically linked by an internal shaft that causes them to turn at the same speed. Unlike multiple pumps, in which the input power is mechanical (shaft connected to a motor), in a flow divider the input power is of a fluid-mechanical nature, i.e. a flow of oil under pressure parallelly supplies the modular elements, which are in turn connected to the hydraulic circuits serving the users. The portion of flow utilized by each element is solely determined by its nominal flow rate. Therefore, unlike standard static dividers with variable ports, the flow dividers do not cause dissipation and are also much more precise. The use of flow dividers in a system reduces the number of pumps necessary as well as the associated individual mechanical power takeoffs and complex mechanical couplers (with greater losses). Leaving aside small losses for the time being, at any given moment the total input power is equal to the sum of the powers supplied by all elements making up the flow divider. Therefore, if in an interval of time the power required by a hydraulic circuit is equal to zero (inactive drained circuit), the power supplied by the element feeding that circuit becomes available for the other elements, which may use it in their own circuits, also operating at higher pressures than the intake pressure.

### Most frequent applications of flow dividers

Supply of two or more independent hydraulic circuits by means of a single pump, with an overall flow rate equal to the sum of the flow rates.

Examples of this kind of application:

- lifting platforms and bridges;
- hydraulic bending presses and shearing machines;
- hoisting of freight containers;
- lubrication systems;
- hydraulic opening / closing of gates;
- automatic hydraulically-driven machines;
- actuation of formwork for construction;
- wood processing machinery;
- conveyance of trolleys driven by hydraulic cylinders or motors;
- equipment for the food industry;
- military installations.

Pressure amplifiers.

When in a hydraulic system one user requires a much higher operating or peak pressure than all the others, it is more convenient to supply it by means of a flow divider than to upgrade the whole system to work with higher pressure.

With a two-element flow divider flow may be discharged from the outlet of one element so that the pressure in the other will become much higher than that of the pump supplying the system.

Examples of this kind of application:

- presses with rapid approach
- machine tools

### Constructive features

FLOW DIVIDER BODY FLANGE AND COVER	Extruded alloy Serie 7000, heat treated and anodised	Rp=345 N/mm <sup>2</sup> (Yield Strength) Rm=382 N/mm <sup>2</sup> (Breaking Strength)
GEAR BUSH BEARINGS	Special Heat Treated tin alloy with excellent mechanical features and high anti-friction capacity. Self-lubricating bushes DU	Rp=350 N/mm <sup>2</sup> (Yield Strength) Rm=390 N/mm <sup>2</sup> (Breaking Strength)
GEARS	Steel UNI 7846	Rs=980 N/mm <sup>2</sup> (Yield Strength) Rm=1 270÷1 570 N/mm <sup>2</sup> (Breaking Strength)
GASKET	A 727 Acrolonitrile Standard F 975 Viton FKM	90 Shore, thermal resistance 120°C 80 Shore, thermal resistance 200°C



Flow divider (Standard Version)

Code:

9RD	NN	CC
-----	----	----

9RD	Flow Divider Typology
NN	Number of elements
CC	Displacement Code

Example: Flow divider with two elements (same displacement):

RV-2D/11 x 2

9RD	02	47
-----	----	----

Example: Flow Divider with 4 elements with different displacement (max 7):

RV-2D/9+14+14+22

9RD	04	45	49	49	55
-----	----	----	----	----	----

NOTE: to define codes for flow dividers with more than 7 different displacement, please contact our sales department.

Table: 1

Displacement Cm <sup>3</sup> /rev	CC Code	Max Pressure bar	One element flow rate l/min		
			MIN	RECOMMENDED	MAX
4	41	210	4,8	7,6	10
6	43	210	7,2	10,8	15
9	45	210	10,8	15,1	22,5
11	47	210	13,2	19,4	27,5
14	49	200	16,8	25,9	35
17	51	200	20,4	30,2	42,5
19	53	190	22,8	34,6	47,5
22	55	180	26,4	41	55
26	57	160	31,2	45,4	65
30	59	160	36	54	75
34	61	140	40,8	61,6	85
40	63	130	48	71,3	100

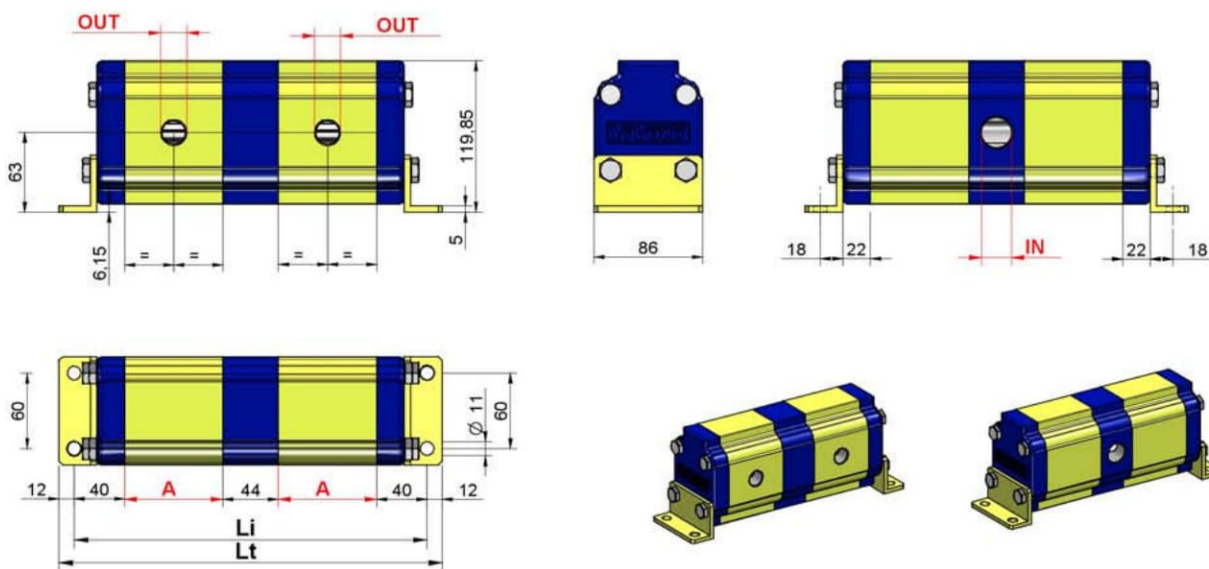

REFERENCES: RD201

Table: 2

Li = Distance between fixing hole centres (single displacement flow divider)

Cm <sup>3</sup> /rev	A	IN	OUT	Number of elements															
				2	3	4	5	6	7	8	9	10	11	12	13	14	15	16	
4	47	3/4 BSP	1/2 BSP	218	309	400	491	582	673	764	855	946	1037	1128	1219	1310	1401	1492	
6	50	3/4 BSP	1/2 BSP	224	318	412	506	600	694	788	882	976	1070	1164	1258	1352	1446	1540	
9	54	3/4 BSP	1/2 BSP	232	330	428	526	624	722	820	918	1016	1114	1212	1310	1408	1506	1604	
11	58	3/4 BSP	1/2 BSP	240	342	444	546	648	750	852	954	1056	1158	1260	1362	1464	1566	1668	
14	64	3/4 BSP	1/2 BSP	252	360	468	576	684	792	900	1008	1116	1224	1332	1440	1548	1656	1764	
17	68	3/4 BSP	1/2 BSP	260	372	484	596	708	820	932	1044	1156	1268	1380	1492	1604	1716	1828	
19	72	3/4 BSP	1/2 BSP	268	384	500	616	732	848	964	1080	1196	1312	1428	1544	1660	1776	1892	
22	78	3/4 BSP	1/2 BSP	280	402	524	646	768	890	1012	1134	1256	1378	1500	1622	1744	1866	1988	
26	82	1 BSP	3/4 BSP	288	414	540	666	792	918	1044	1170	1296	1422	1548	1674	1800	1926	2052	
30	90	1 BSP	3/4 BSP	304	438	572	706	840	974	1108	1242	1376	1510	1644	1778	1912	2046	2180	
34	97	1 BSP	3/4 BSP	318	459	600	741	882	1023	1164	1305	1446	1587	1728	1869	2010	2151	2292	
40	106	1 BSP	3/4 BSP	336	486	636	786	936	1086	1236	1386	1536	1686	1836	1986	2136	2286	2436	

Table: 3 in this table the number of inlets in function of the number of elements are indicated.

Number of elements	2	3	4	5	6	7	8	9	10	11	12	13	14	15	16
"IN" Number of inlets	1	1	2	2	3	3	4	4	5	5	6	6	7	7	8

Flow divider (Standard Version)

INTERNAL DRAIN

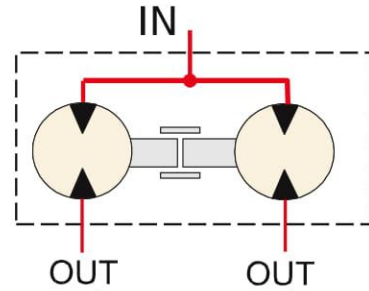
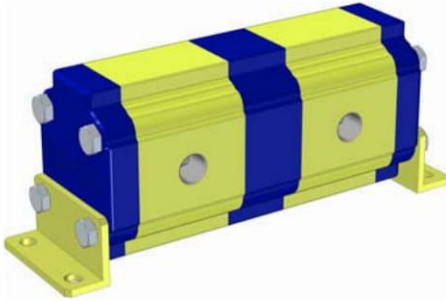

In table 1 the functioning range of single flow divider elements is indicated.

The higher is the feeding capacity ( q ), the higher is the precision of flow division, but in opposition there are losses of loading and higher noise. Therefore we suggest to feed the elements with capacities equal or a few superior to the ones indicated in the column "RECOMMENDED".

It's important remember to verify the capacities even in phase of flow reunion.

The pressures indicated are to be considered as maximum of functioning, the flow divider is able to bear peaks of pressure 20% superior.

How to calculate the "Li" and "Lt" measures of flow dividers:

From table 2 it is possible to obtain the "Li" measure for flow dividers up to 16 elements with equal displacements; for flow dividers with different elements or with more than 16 elements the "Li" and "Lt" measure have to be calculated by the following formula:

$$Li = [(n-1) \times 44] + 80 + (A1 + A2 + A3 + \dots)$$

$$80 = 40 + 40$$

n = Number of elements of flow divider  
 A1 ... An = heights of elements of flow divider

$$Lt = Li + 24$$

$$24 = 12 + 12$$

EXAMPLE: To obtain the measures Li and Lt of a flow divider with three elements (n=3), RV-2D 19 + 11 + 9

Distance between fixing hole centres       $Li = [(3-1) \times 44] + 80 + 72 + 58 + 54 = 352 \text{ mm}$

Total Length       $Lt = 352 + 24 = 376 \text{ mm}$

In table 3 the number of inlets in function of the number of elements are indicated.

For flow dividers with many inlets, as they are all communicating it is even possible to use only one of them, by plugging the other ones. We suggest to use at least one 3/4" BSP inlet every 80 l/min capacity and at least one 1" BSP inlet every 120 l/min capacity

To obtain errors of division inferior to 3% there must be no difference of pressure between the elements superior to 30 bar. To obtain high precisions the respect of the following parameters is also important:

- Environment temperature: -10°C ÷ +60°C      Oil temperature: +30°C ÷ +60°C
- Hydraulic oil based on hlp, hv (din 51524) minerals      Oil Viscosity 20 ÷ 40 cSt
- Oil filtering 10 ÷ 25 µ



Flow divider with independent phase correction and anticavitation valves for each element

Codice:

9RV	NN	M	CC
-----	----	---	----

9RV	Flow Divider Typology
NN	Number of elements
M	Code of setting range of the valves
CC	Displacement Code

TABELLA "M"	
A	10 ÷ 105 bar
B	70 ÷ 210 bar
C	140 ÷ 350 bar

Example: Flow divider with two elements (same displacement):  
RV-2V/11 x 2 with valve 10 ÷ 105 bar

9RV	02	A	47
-----	----	---	----

Example: Flow Divider with 4 elements with different displacement (max 7):  
RV-2V/9+14+14+22 with valve 70 ÷ 210 bar

9RV	04	B	45	49	49	55
-----	----	---	----	----	----	----

NOTE: to define codes for flow dividers with more than 7 different displacement, please contact our sales department.

Table: 1

Displacement Cm <sup>3</sup> /rev	CC Code	Max Pressure bar	One element flow rate l/min		
			MIN	RECOMMENDED	MAX
4	41	210	4,8	7,6	10
6	43	210	7,2	10,8	15
9	45	210	10,8	15,1	22,5
11	47	210	13,2	19,4	27,5
14	49	200	16,8	25,9	35
17	51	200	20,4	30,2	42,5
19	53	190	22,8	34,6	47,5
22	55	180	26,4	41	55
26	57	160	31,2	45,4	65
30	59	160	36	54	75
34	61	140	40,8	61,6	85
40	63	130	48	71,3	100

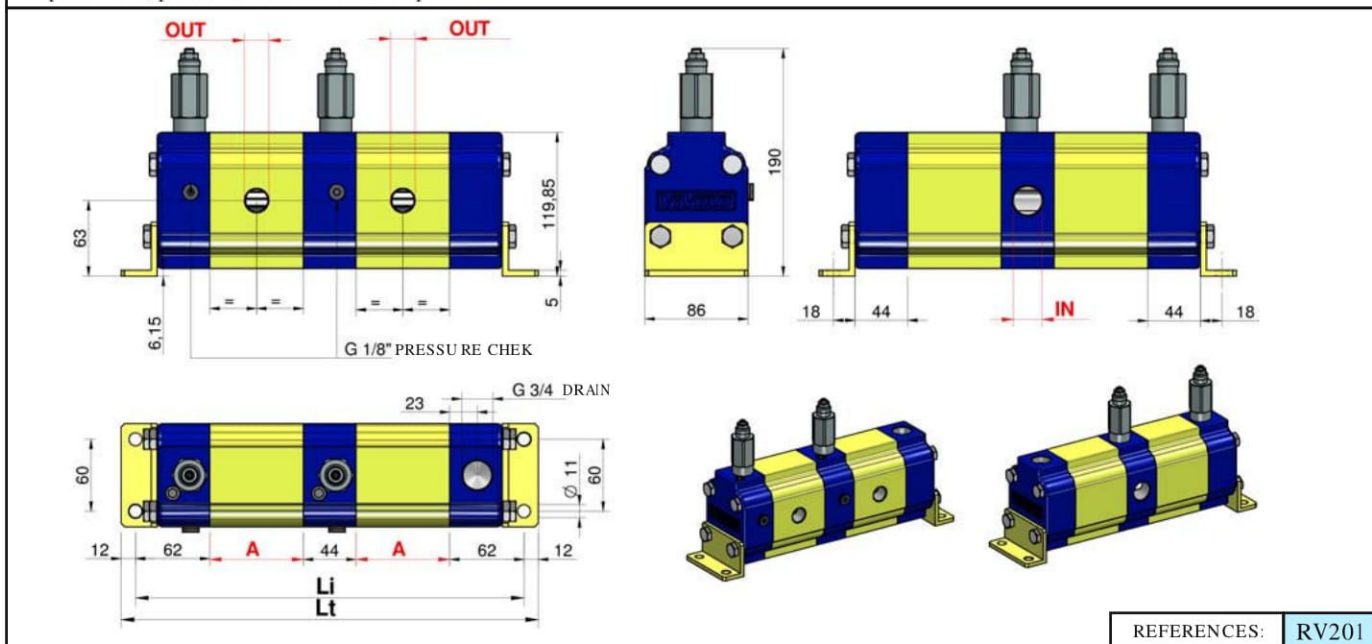

REFERENCES: RV201

Table: 2

Li = Distance between fixing hole centres (single displacement flow divider)

Cm <sup>3</sup> /rev	A	IN	OUT	Number of elements															
				2	3	4	5	6	7	8	9	10	11	12	13	14	15	16	
4	47	3/4 BSP	1/2 BSP	262	353	444	535	626	717	808	899	990	1081	1172	1263	1354	1445	1536	
6	50	3/4 BSP	1/2 BSP	268	362	456	550	644	738	832	926	1020	1114	1208	1302	1396	1490	1584	
9	54	3/4 BSP	1/2 BSP	276	374	472	570	668	766	864	962	1060	1158	1256	1354	1452	1550	1648	
11	58	3/4 BSP	1/2 BSP	284	386	488	590	692	794	896	998	1100	1202	1304	1406	1508	1610	1712	
14	64	3/4 BSP	1/2 BSP	296	404	512	620	728	836	944	1052	1160	1268	1376	1484	1592	1700	1808	
17	68	3/4 BSP	1/2 BSP	304	416	528	640	752	864	976	1088	1200	1312	1424	1536	1648	1760	1872	
19	72	3/4 BSP	1/2 BSP	312	428	544	660	776	892	1008	1124	1240	1356	1472	1588	1704	1820	1936	
22	78	3/4 BSP	1/2 BSP	324	446	568	690	812	934	1056	1178	1300	1422	1544	1666	1788	1910	2032	
26	82	1 BSP	3/4 BSP	332	458	584	710	836	962	1088	1214	1340	1466	1592	1718	1844	1970	2096	
30	90	1 BSP	3/4 BSP	348	482	616	750	884	1018	1152	1286	1420	1554	1688	1822	1956	2090	2224	
34	97	1 BSP	3/4 BSP	362	503	644	785	926	1067	1208	1349	1490	1631	1772	1913	2054	2195	2336	
40	106	1 BSP	3/4 BSP	380	530	680	830	980	1130	1280	1430	1580	1730	1880	2030	2180	2330	2480	

Table: 3 in this table the number of inlets in function of the number of elements are indicated.

Number of elements	2	3	4	5	6	7	8	9	10	11	12	13	14	15	16
"IN" Number of inlets	1	1	2	2	3	3	4	4	5	5	6	6	7	7	8

Flow divider with independent phase correction and anticavitation valves for each element

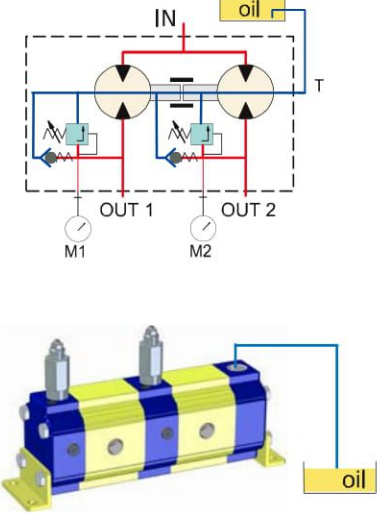
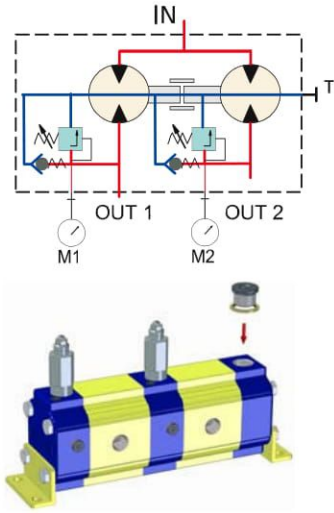
EXTERNAL DRAIN <i>STANDARD SETUP</i>	INTERNAL DRAIN
<p>For the correct functioning of the flow divider, it has to be installed <i>under the oil level</i>. The drain tube has to pick up under the oil level and it has not to aspire air.</p>	<p>To predispose the divider to the internal drain, plug the 3/4" G drain port ( T ) Note: with this configuration the function of anticavitation valves is annulled</p>
	

In table 1 the functioning range of single flow divider elements is indicated .

The higher is the feeding capacity ( q ), the higher is the precision of flow division, but in opposition there are losses of loading and higher noise. Therefore we suggest to feed the elements with capacities equal or a few superior to the ones indicated in the column "RECOMMENDED".

It's important remember to verify the capacities even in phase of flow reunion.

The pressures indicated are to be considered as maximum of functioning, the flow divider is able to bear peaks of pressure 20% superior.

How to calculate the "Li" and "Lt" measures of flow dividers:

From table 2 it is possible to obtain the "Li" measure for flow dividers up to 16 elements with equal displacements; for flow dividers with different elements or with more than 16 elements the "Li" and "Lt" measure have to be calculated by the following formula:

$$Li = [(n-1) \times 44] + 124 + (A1 + A2 + A3 + \dots)$$

$$124 = 62 + 62$$

n = Number of elements of flow divider

A1 ... An = heights of elements of flow divider

$$Lt = Li + 24$$

$$24 = 12 + 12$$

EXAMPLE: To obtain the measures Li and Lt of a flow divider with three elements (n=3), RV-2V 19 + 11 + 9

Distance between fixing hole centres

$$Li = [(3-1) \times 44] + 124 + 72 + 58 + 54 = 396 \text{ mm}$$

Total Length

$$Lt = 396 + 24 = 420 \text{ mm}$$

In table 3 the number of inlets in function of the number of elements are indicated .

For flow dividers with many inlets, as they are all communicating it is even possible to use only one of them, by plugging the other ones. We suggest to use at least one 3/4" BSP inlet every 80 l/min capacity and at least one 1" BSP inlet every 120 l/min capacity

To obtain errors of division inferior to 3% there must be no difference of pressure between the elements superior to 30 bar. To obtain high precisions the respect of the following parameters is also important:

- Environment temperature: -10°C ÷ +60°C                      Oil temperature: +30°C ÷ +60°C
- Hydraulic oil based on hlp, hv (din 51524) minerals      Oil Viscosity 20 ÷ 40 cSt
- Oil filtering 10 ÷ 25 μ