

**DIVISEUR DE DEBIT TYPE STANDARD**  
GEAR FLOW DIVIDER STANDARD TYPE  
DIVISOR DE FLUJO TIPO ESTANDAR

**RV2D**

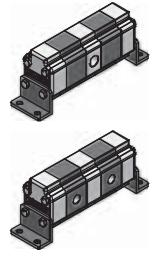

**DIVISEUR DE DEBIT AVEC LIMITEUR DE PRESSION PAR ELEMENT**  
GEAR FLOW DIVIDER WITH RELIEF VALVE ON EACH ELEMENT  
DIVISOR DE FLUJO CON VALVULA LIMITADORA DE PRESION EN CADA ELEMENTO

**RV2V**

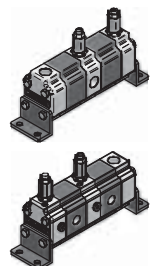
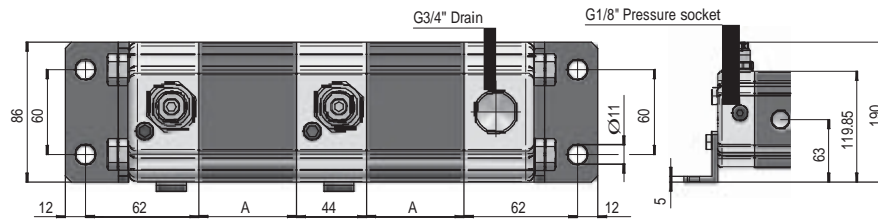

| Type<br>Type<br>Tipo | cm <sup>3</sup> /tr<br>cm <sup>3</sup> /rev<br>cm <sup>3</sup> /giro | Q<br>l/min per element |         |      | P MAX<br>bar | A   | IN<br>BSP | OUT<br>BSP | kg    |
|----------------------|--|------------------------|---------|------|--------------|-----|-----------|------------|-------|
|                      |  | Min.                   | Optimal | Max. |              |     |           |            |       |
| RV 2 - (D-V) 4       | 4,0  | 4,8                    | 7,6     | 10   | 210          | 47  | 3/4"      | 1/2"       | ~2,20 |
| RV 2 - (D-V) 6       | 6,0  | 7,2                    | 10,8    | 15   | 210          | 50  | 3/4"      | 1/2"       | ~2,30 |
| RV 2 - (D-V) 9       | 9,0  | 10,8                   | 15,1    | 22,5 | 210          | 54  | 3/4"      | 1/2"       | ~2,40 |
| RV 2 - (D-V) 11      | 11,0   | 13,2                   | 19,4    | 27,5 | 210          | 58  | 3/4"      | 1/2"       | ~2,50 |
| RV 2 - (D-V) 14      | 14,0   | 16,8                   | 25,9    | 35   | 200          | 64  | 3/4"      | 1/2"       | ~2,70 |
| RV 2 - (D-V) 17      | 17,0   | 20,4                   | 30,2    | 42,5 | 200          | 68  | 3/4"      | 1/2"       | ~2,80 |
| RV 2 - (D-V) 19      | 19,0   | 22,8                   | 34,6    | 47,5 | 190          | 72  | 3/4"      | 1/2"       | ~2,90 |
| RV 2 - (D-V) 22      | 22,0   | 26,4                   | 41,0    | 55   | 180          | 78  | 3/4"      | 1/2"       | ~3,05 |
| RV 2 - (D-V) 26      | 26,0   | 31,2                   | 45,4    | 65   | 160          | 82  | 1"        | 3/4"       | ~3,15 |
| RV 2 - (D-V) 30      | 30,0   | 36,0                   | 54,0    | 75   | 160          | 90  | 1"        | 3/4"       | ~3,40 |
| RV 2 - (D-V) 34      | 34,0   | 40,8                   | 61,6    | 85   | 140          | 97  | 1"        | 3/4"       | ~3,60 |
| RV 2 - (D-V) 40      | 40,0   | 48,0                   | 71,3    | 100  | 130          | 106 | 1"        | 3/4"       | ~3,80 |

Les données du tableau se réfèrent à chaque élément.  
The data of the table refer to a single element.  
Los datos del cuadro se refieren a cada elemento.

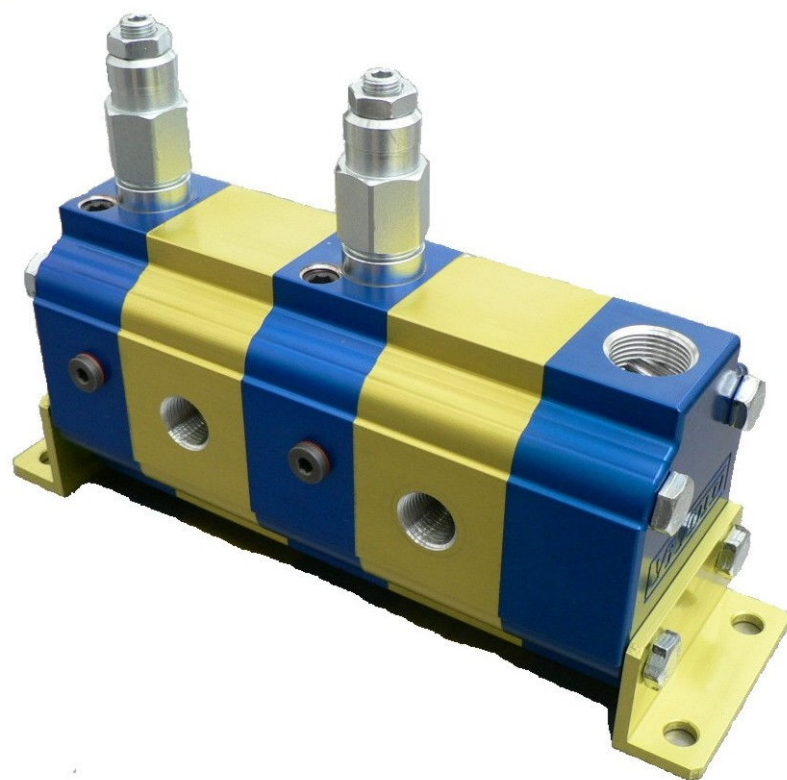
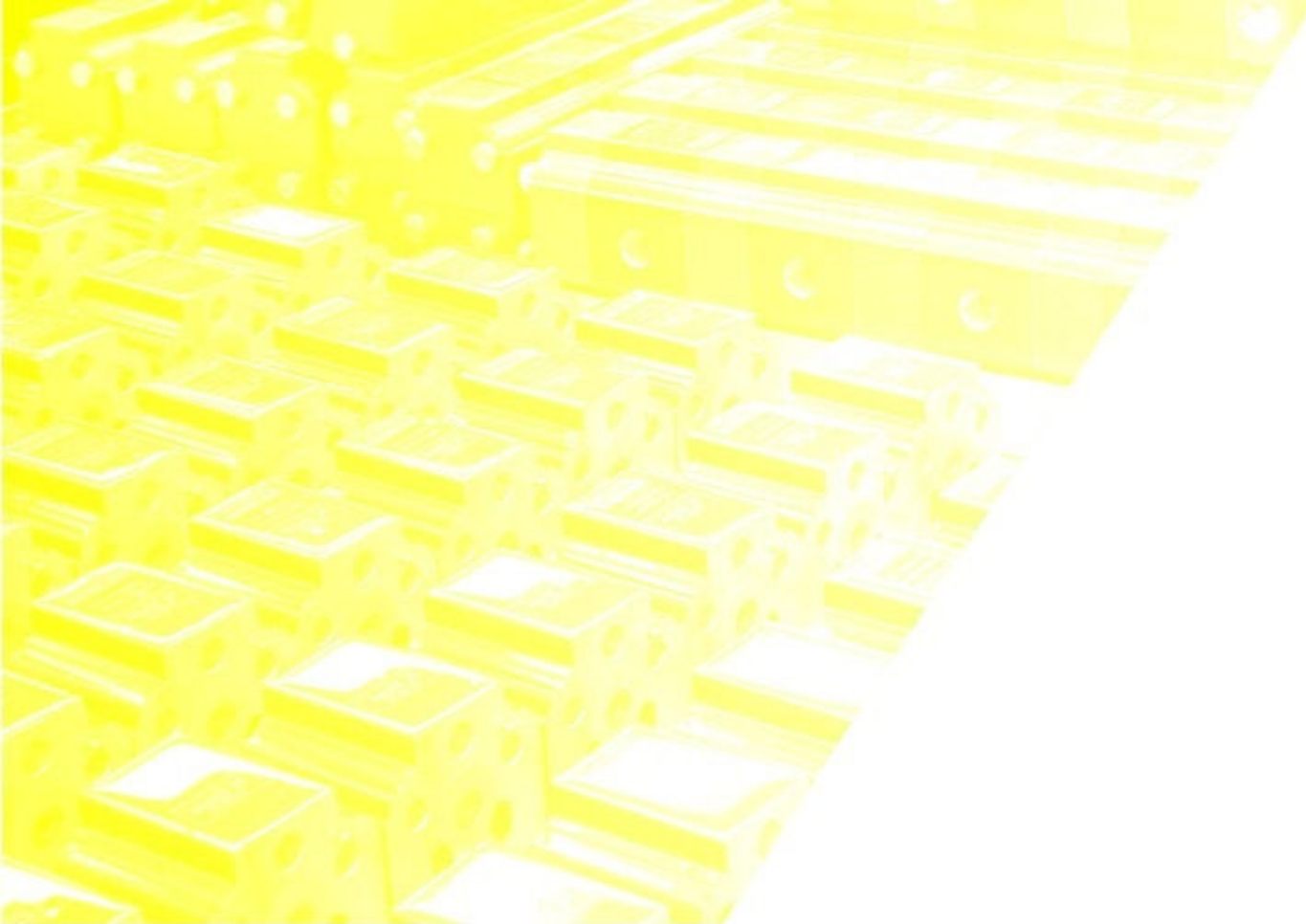

## FLOW DIVIDERS "RV-2 serie"



ENGLISH

VERS:26-03-2010

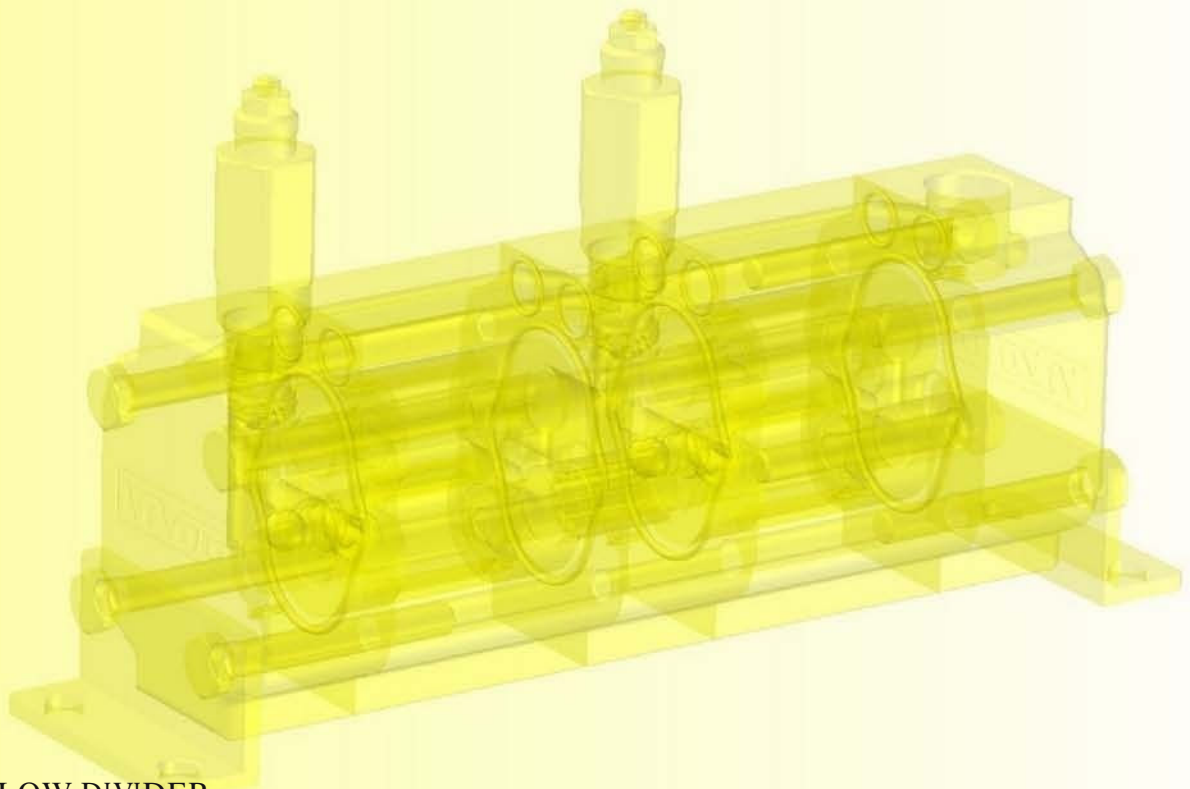

### **RV-D** FLOW DIVIDER

This is the flow divider standard version, it simply divide the incoming flow without allowing the phase correction

### **RV-V** FLOW DIVIDER with phase correction and anticavitation valves

In this version the flow divider has one phase correction and anticavitation valve for each element, this allow a flow correction in both direction (flow division and flow unification). In addition it can adjust the relief pressure to a different value for each element.

### **RV-G** FLOW DIVIDER + MOTOR

The RV-G typology is the motorized version of the RV-D divider. It has a motor conneted to the flow divider elements. This solution is important when the incoming and/or outgoing pressure is below the minimum pressure required to start. Giving flow to the motor, help the flow divider rotation start. Typical use: plants with single effects hydraulic jack.

### **RV-N** FLOW DIVIDER with phase correction and anticavitation valves + MOTOR

This is the motorized version of the RV-V divider.

The motor has the same funcion that is described for the RV-G divider.

The flow division error is lower than  $\pm 1.5\%$  with a pressure difference between one element and another until 30 Bars. For bigger differences we can approximate an error increase of 1 % for each 10 additional bars.

A flow divider is made up of two or more modular elements (sections) with gears mechanically linked by an internal shaft that causes them to turn at the same speed.

Unlike multiple pumps, in which the input power is mechanical (shaft connected to a motor), in a flow divider the input power is of a fluid-mechanical nature, i.e. a flow of oil under pressure parallelly supplies the modular elements, which are in turn connected to the hydraulic circuits serving the users.

The portion of flow utilized by each element is solely determined by its nominal flow rate. Therefore, unlike standard static dividers with variable ports, the flow dividers do not cause dissipation and are also much more precise.

The use of flow dividers in a system reduces the number of pumps necessary as well as the associated individual mechanical power takeoffs and complex mechanical couplers (with greater losses).

Leaving aside small losses for the time being, at any given moment the total input power is equal to the sum of the powers supplied by all elements making up the flow divider.

Therefore, if in an interval of time the power required by a hydraulic circuit is equal to zero (inactive drained circuit), the power supplied by the element feeding that circuit becomes available for the other elements, which may use it in their own circuits, also operating at higher pressures than the intake pressure.

### Most frequent applications of flow dividers

Supply of two or more independent hydraulic circuits by means of a single pump, with an overall flow rate equal to the sum of the flow rates.

Examples of this kind of application:

- lifting platforms and bridges;
- hydraulic bending presses and shearing machines;
- hoisting of freight containers;
- lubrication systems;
- hydraulic opening / closing of gates;
- automatic hydraulically-driven machines;
- actuation of formwork for construction;
- wood processing machinery;
- conveyance of trolleys driven by hydraulic cylinders or motors;
- equipment for the food industry;
- military installations.

Pressure amplifiers.

When in a hydraulic system one user requires a much higher operating or peak pressure than all the others, it is more convenient to supply it by means of a flow divider than to upgrade the whole system to work with higher pressure.

With a two-element flow divider flow may be discharged from the outlet of one element so that the pressure in the other will become much higher than that of the pump supplying the system.

Examples of this kind of application:

- presses with rapid approach
- machine tools

### Constructive features

|                                       |  |   |
|---------------------------------------|--|---|
| FLOW DIVIDER BODY<br>FLANGE AND COVER | Extruded alloy Serie 7000, heat treated and anodised   | Rp=345 N/mm <sup>2</sup> (Yield Strength)<br>Rm=382 N/mm <sup>2</sup> (Breaking Strength)         |
| GEAR BUSH BEARINGS                    | Special Heat Treated tin alloy with excellent mechanical features and high anti-friction capacity.<br>Self-lubricating bushes DU | Rp=350 N/mm <sup>2</sup> (Yield Strength)<br>Rm=390 N/mm <sup>2</sup> (Breaking Strength)         |
| GEARS                                 | Steel UNI 7846   | Rs=980 N/mm <sup>2</sup> (Yield Strength)<br>Rm=1 270÷1 570 N/mm <sup>2</sup> (Breaking Strength) |
| GASKET                                | A 727 Acrolonitrile Standard<br>F 975 Viton FKM  | 90 Shore, thermal resistance 120°C<br>80 Shore, thermal resistance 200°C                          |



Flow divider (Standard Version)

Code:

|     |    |    |
|-----|----|----|
| 9RD | NN | CC |
|-----|----|----|

|     |                       |
|-----|-----------------------|
| 9RD | Flow Divider Typology |
| NN  | Number of elements    |
| CC  | Displacement Code     |

Example: Flow divider with two elements (same displacement):  
RV-2D/11 x 2

|     |    |    |
|-----|----|----|
| 9RD | 02 | 47 |
|-----|----|----|

Example: Flow Divider with 4 elements with different displacement (max 7):  
RV-2D/9+14+14+22

|     |    |    |    |    |    |
|-----|----|----|----|----|----|
| 9RD | 04 | 45 | 49 | 49 | 55 |
|-----|----|----|----|----|----|

NOTE: to define codes for flow dividers with more than 7 different displacement, please contact our sales department.

Table: 1

| Displacement<br>Cm <sup>3</sup> /rev | CC<br>Code | Max<br>Pressure<br>bar | One element flow rate<br>l/min |             |      |
|--------------------------------------|------------|------------------------|--------------------------------|-------------|------|
|                                      |            |                        | MIN                            | RECOMMENDED | MAX  |
| 4                                    | 41         | 210                    | 4,8                            | 7,6         | 10   |
| 6                                    | 43         | 210                    | 7,2                            | 10,8        | 15   |
| 9                                    | 45         | 210                    | 10,8                           | 15,1        | 22,5 |
| 11                                   | 47         | 210                    | 13,2                           | 19,4        | 27,5 |
| 14                                   | 49         | 200                    | 16,8                           | 25,9        | 35   |
| 17                                   | 51         | 200                    | 20,4                           | 30,2        | 42,5 |
| 19                                   | 53         | 190                    | 22,8                           | 34,6        | 47,5 |
| 22                                   | 55         | 180                    | 26,4                           | 41          | 55   |
| 26                                   | 57         | 160                    | 31,2                           | 45,4        | 65   |
| 30                                   | 59         | 160                    | 36                             | 54          | 75   |
| 34                                   | 61         | 140                    | 40,8                           | 61,6        | 85   |
| 40                                   | 63         | 130                    | 48                             | 71,3        | 100  |

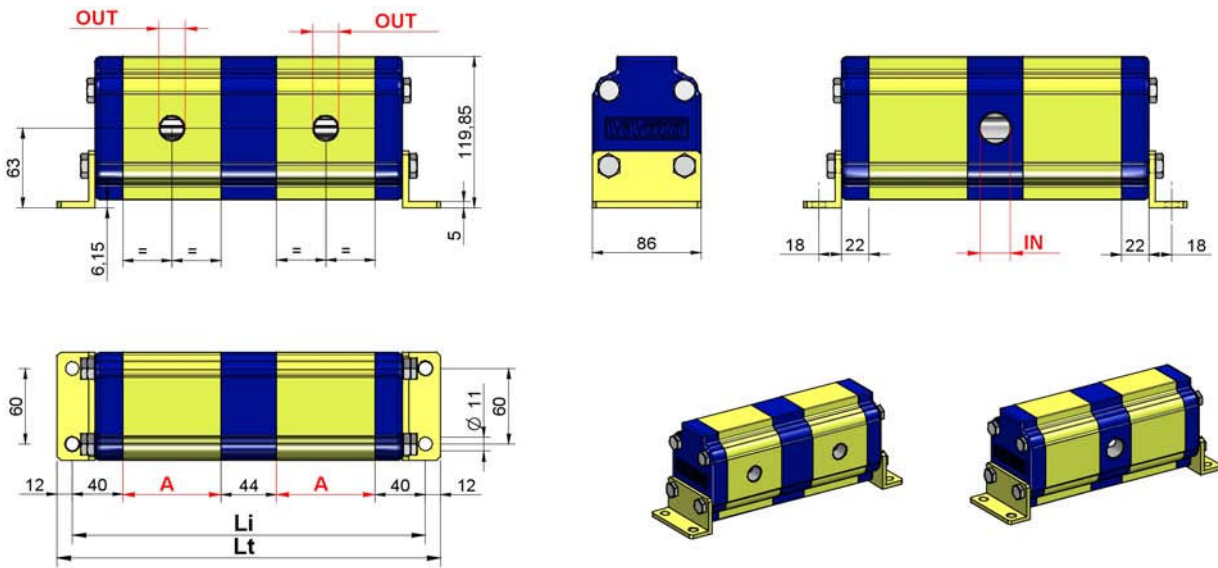

REFERENCES: RD201

Table: 2

Li = Distance between fixing hole centres (single displacement flow divider)

| Cm <sup>3</sup> /rev | A   | IN      | OUT     | Number of elements |     |     |     |     |      |      |      |      |      |      |      |      |      |      |  |
|----------------------|-----|---------|---------|--------------------|-----|-----|-----|-----|------|------|------|------|------|------|------|------|------|------|--|
|                      |     |         |         | 2                  | 3   | 4   | 5   | 6   | 7    | 8    | 9    | 10   | 11   | 12   | 13   | 14   | 15   | 16   |  |
| 4                    | 47  | 3/4 BSP | 1/2 BSP | 218                | 309 | 400 | 491 | 582 | 673  | 764  | 855  | 946  | 1037 | 1128 | 1219 | 1310 | 1401 | 1492 |  |
| 6                    | 50  | 3/4 BSP | 1/2 BSP | 224                | 318 | 412 | 506 | 600 | 694  | 788  | 882  | 976  | 1070 | 1164 | 1258 | 1352 | 1446 | 1540 |  |
| 9                    | 54  | 3/4 BSP | 1/2 BSP | 232                | 330 | 428 | 526 | 624 | 722  | 820  | 918  | 1016 | 1114 | 1212 | 1310 | 1408 | 1506 | 1604 |  |
| 11                   | 58  | 3/4 BSP | 1/2 BSP | 240                | 342 | 444 | 546 | 648 | 750  | 852  | 954  | 1056 | 1158 | 1260 | 1362 | 1464 | 1566 | 1668 |  |
| 14                   | 64  | 3/4 BSP | 1/2 BSP | 252                | 360 | 468 | 576 | 684 | 792  | 900  | 1008 | 1116 | 1224 | 1332 | 1440 | 1548 | 1656 | 1764 |  |
| 17                   | 68  | 3/4 BSP | 1/2 BSP | 260                | 372 | 484 | 596 | 708 | 820  | 932  | 1044 | 1156 | 1268 | 1380 | 1492 | 1604 | 1716 | 1828 |  |
| 19                   | 72  | 3/4 BSP | 1/2 BSP | 268                | 384 | 500 | 616 | 732 | 848  | 964  | 1080 | 1196 | 1312 | 1428 | 1544 | 1660 | 1776 | 1892 |  |
| 22                   | 78  | 3/4 BSP | 1/2 BSP | 280                | 402 | 524 | 646 | 768 | 890  | 1012 | 1134 | 1256 | 1378 | 1500 | 1622 | 1744 | 1866 | 1988 |  |
| 26                   | 82  | 1 BSP   | 3/4 BSP | 288                | 414 | 540 | 666 | 792 | 918  | 1044 | 1170 | 1296 | 1422 | 1548 | 1674 | 1800 | 1926 | 2052 |  |
| 30                   | 90  | 1 BSP   | 3/4 BSP | 304                | 438 | 572 | 706 | 840 | 974  | 1108 | 1242 | 1376 | 1510 | 1644 | 1778 | 1912 | 2046 | 2180 |  |
| 34                   | 97  | 1 BSP   | 3/4 BSP | 318                | 459 | 600 | 741 | 882 | 1023 | 1164 | 1305 | 1446 | 1587 | 1728 | 1869 | 2010 | 2151 | 2292 |  |
| 40                   | 106 | 1 BSP   | 3/4 BSP | 336                | 486 | 636 | 786 | 936 | 1086 | 1236 | 1386 | 1536 | 1686 | 1836 | 1986 | 2136 | 2286 | 2436 |  |

Table: 3 in this table the number of inlets in function of the number of elements are indicated.

| Number of elements    | 2 | 3 | 4 | 5 | 6 | 7 | 8 | 9 | 10 | 11 | 12 | 13 | 14 | 15 | 16 |
|-----------------------|---|---|---|---|---|---|---|---|----|----|----|----|----|----|----|
| "IN" Number of inlets | 1 | 1 | 2 | 2 | 3 | 3 | 4 | 4 | 5  | 5  | 6  | 6  | 7  | 7  | 8  |

Flow divider (Standard Version)

**INTERNAL DRAIN**

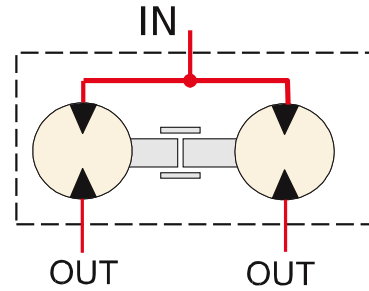
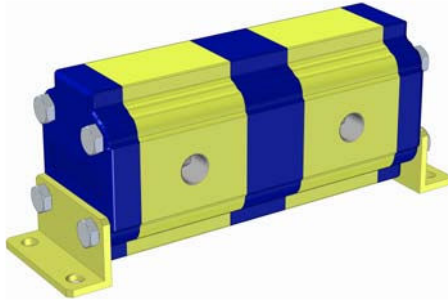

In table 1 the functioning range of single flow divider elements is indicated.

The higher is the feeding capacity ( q ), the higher is the precision of flow division, but in opposition there are losses of loading and higher noise. Therefore we suggest to feed the elements with capacities equal or a few superior to the ones indicated in the column "RECOMMENDED".

It's important remember to verify the capacities even in phase of flow reunion.

The pressures indicated are to be considered as maximum of functioning, the flow divider is able to bear peaks of pressure 20% superior.

How to calculate the "Li" and "Lt" measures of flow dividers:

From table 2 it is possible to obtain the "Li" measure for flow dividers up to 16 elements with equal displacements; for flow dividers with different elements or with more than 16 elements the "Li" and "Lt" measure have to be calculated by the following formula:

$$Li = [(n-1) \times 44] + 80 + (A1 + A2 + A3 + \dots)$$

$$80 = 40 + 40$$

n = Number of elements of flow divider

A1 ... An = heights of elements of flow divider

$$Lt = Li + 24$$

$$24 = 12 + 12$$

EXAMPLE: To obtain the measures Li and Lt of a flow divider with three elements (n=3), RV-2D 19 + 11 + 9

Distance between fixing hole centres       $Li = [(3-1) \times 44] + 80 + 72 + 58 + 54 = 352 \text{ mm}$

Total Length       $Lt = 352 + 24 = 376 \text{ mm}$

In table 3 the number of inlets in function of the number of elements are indicated.

For flow dividers with many inlets, as they are all communicating it is even possible to use only one of them, by plugging the other ones. We suggest to use at least one 3/4" BSP inlet every 80 l/min capacity and at least one 1" BSP inlet every 120 l/min capacity

To obtain errors of division inferior to 3% there must be no difference of pressure between the elements superior to 30 bar. To obtain high precisions the respect of the following parameters is also important:

- Environment temperature: -10°C ÷ +60°C      Oil temperature: +30°C ÷ +60°C
- Hydraulic oil based on hlp, hv (din 51524) minerals      Oil Viscosity 20 ÷ 40 cSt
- Oil filtering 10 ÷ 25 µ

Flow divider with independent phase correction and anticavitation valves for each element

Codice:

|     |    |   |    |
|-----|----|---|----|
| 9RV | NN | M | CC |
|-----|----|---|----|

|     |                                     |
|-----|-------------------------------------|
| 9RV | Flow Divider Typology               |
| NN  | Number of elements                  |
| M   | Code of setting range of the valves |
| CC  | Displacement Code                   |

| TABELLA "M" |               |
|-------------|---------------|
| A           | 10 ÷ 105 bar  |
| B           | 70 ÷ 210 bar  |
| C           | 140 ÷ 350 bar |

Example: Flow divider with two elements (same displacement):  
RV-2V/11 x 2 with valve 10 ÷ 105 bar

|     |    |   |    |
|-----|----|---|----|
| 9RV | 02 | A | 47 |
|-----|----|---|----|

Example: Flow Divider with 4 elements with different displacement (max 7):  
RV-2V/9+14+14+22 with valve 70 ÷ 210 bar

|     |    |   |    |    |    |    |
|-----|----|---|----|----|----|----|
| 9RV | 04 | B | 45 | 49 | 49 | 55 |
|-----|----|---|----|----|----|----|

NOTE: to define codes for flow dividers with more than 7 different displacement, please contact our sales department.

Table: 1

| Displacement<br>Cm <sup>3</sup> /rev | CC<br>Code | Max<br>Pressure<br>bar | One element flow rate<br>l/min |             |      |
|--------------------------------------|------------|------------------------|--------------------------------|-------------|------|
|                                      |            |                        | MIN                            | RECOMMENDED | MAX  |
| 4                                    | 41         | 210                    | 4,8                            | 7,6         | 10   |
| 6                                    | 43         | 210                    | 7,2                            | 10,8        | 15   |
| 9                                    | 45         | 210                    | 10,8                           | 15,1        | 22,5 |
| 11                                   | 47         | 210                    | 13,2                           | 19,4        | 27,5 |
| 14                                   | 49         | 200                    | 16,8                           | 25,9        | 35   |
| 17                                   | 51         | 200                    | 20,4                           | 30,2        | 42,5 |
| 19                                   | 53         | 190                    | 22,8                           | 34,6        | 47,5 |
| 22                                   | 55         | 180                    | 26,4                           | 41          | 55   |
| 26                                   | 57         | 160                    | 31,2                           | 45,4        | 65   |
| 30                                   | 59         | 160                    | 36                             | 54          | 75   |
| 34                                   | 61         | 140                    | 40,8                           | 61,6        | 85   |
| 40                                   | 63         | 130                    | 48                             | 71,3        | 100  |

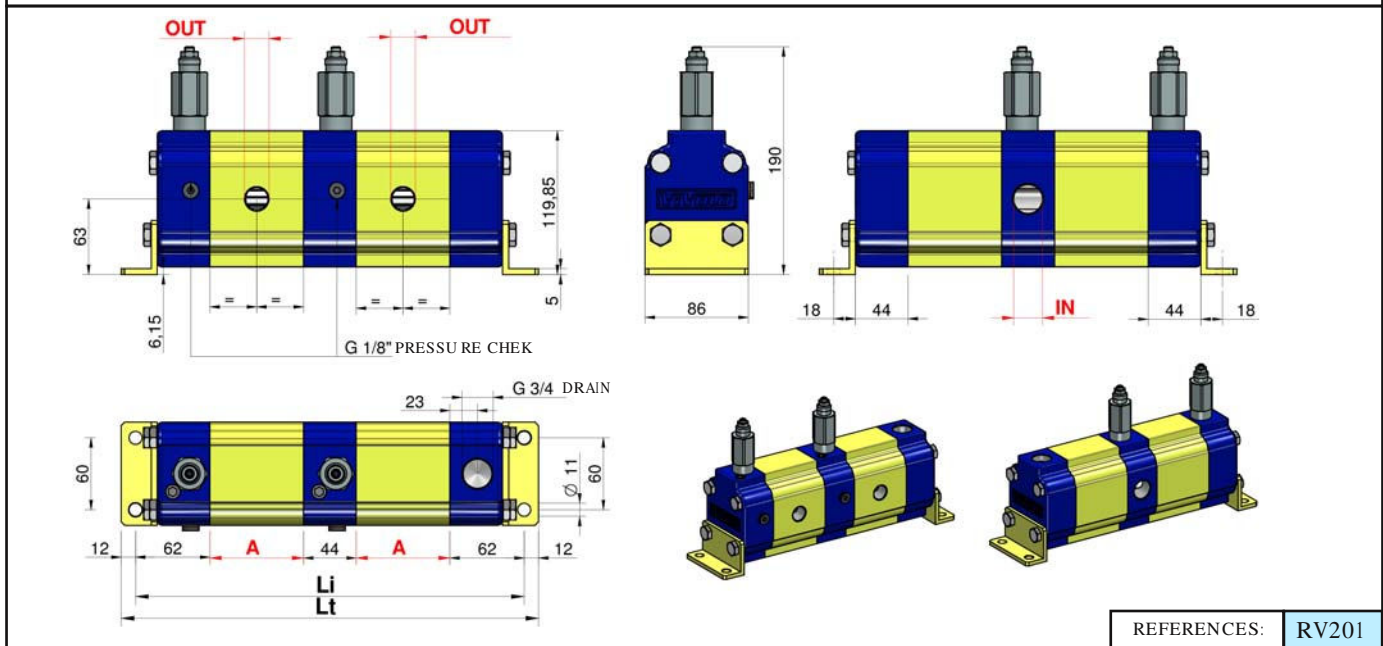

REFERENCES: RV201

Table: 2

Li = Distance between fixing hole centres (single displacement flow divider)

| Cm <sup>3</sup> /rev | A   | IN      | OUT     | Number of elements |     |     |     |     |      |      |      |      |      |      |      |      |      |      |  |
|----------------------|-----|---------|---------|--------------------|-----|-----|-----|-----|------|------|------|------|------|------|------|------|------|------|--|
|                      |     |         |         | 2                  | 3   | 4   | 5   | 6   | 7    | 8    | 9    | 10   | 11   | 12   | 13   | 14   | 15   | 16   |  |
| 4                    | 47  | 3/4 BSP | 1/2 BSP | 262                | 353 | 444 | 535 | 626 | 717  | 808  | 899  | 990  | 1081 | 1172 | 1263 | 1354 | 1445 | 1536 |  |
| 6                    | 50  | 3/4 BSP | 1/2 BSP | 268                | 362 | 456 | 550 | 644 | 738  | 832  | 926  | 1020 | 1114 | 1208 | 1302 | 1396 | 1490 | 1584 |  |
| 9                    | 54  | 3/4 BSP | 1/2 BSP | 276                | 374 | 472 | 570 | 668 | 766  | 864  | 962  | 1060 | 1158 | 1256 | 1354 | 1452 | 1550 | 1648 |  |
| 11                   | 58  | 3/4 BSP | 1/2 BSP | 284                | 386 | 488 | 590 | 692 | 794  | 896  | 998  | 1100 | 1202 | 1304 | 1406 | 1508 | 1610 | 1712 |  |
| 14                   | 64  | 3/4 BSP | 1/2 BSP | 296                | 404 | 512 | 620 | 728 | 836  | 944  | 1052 | 1160 | 1268 | 1376 | 1484 | 1592 | 1700 | 1808 |  |
| 17                   | 68  | 3/4 BSP | 1/2 BSP | 304                | 416 | 528 | 640 | 752 | 864  | 976  | 1088 | 1200 | 1312 | 1424 | 1536 | 1648 | 1760 | 1872 |  |
| 19                   | 72  | 3/4 BSP | 1/2 BSP | 312                | 428 | 544 | 660 | 776 | 892  | 1008 | 1124 | 1240 | 1356 | 1472 | 1588 | 1704 | 1820 | 1936 |  |
| 22                   | 78  | 3/4 BSP | 1/2 BSP | 324                | 446 | 568 | 690 | 812 | 934  | 1056 | 1178 | 1300 | 1422 | 1544 | 1666 | 1788 | 1910 | 2032 |  |
| 26                   | 82  | 1 BSP   | 3/4 BSP | 332                | 458 | 584 | 710 | 836 | 962  | 1088 | 1214 | 1340 | 1466 | 1592 | 1718 | 1844 | 1970 | 2096 |  |
| 30                   | 90  | 1 BSP   | 3/4 BSP | 348                | 482 | 616 | 750 | 884 | 1018 | 1152 | 1286 | 1420 | 1554 | 1688 | 1822 | 1956 | 2090 | 2224 |  |
| 34                   | 97  | 1 BSP   | 3/4 BSP | 362                | 503 | 644 | 785 | 926 | 1067 | 1208 | 1349 | 1490 | 1631 | 1772 | 1913 | 2054 | 2195 | 2336 |  |
| 40                   | 106 | 1 BSP   | 3/4 BSP | 380                | 530 | 680 | 830 | 980 | 1130 | 1280 | 1430 | 1580 | 1730 | 1880 | 2030 | 2180 | 2330 | 2480 |  |

Table: 3 in this table the number of inlets in function of the number of elements are indicated.

| Number of elements    | 2 | 3 | 4 | 5 | 6 | 7 | 8 | 9 | 10 | 11 | 12 | 13 | 14 | 15 | 16 |
|-----------------------|---|---|---|---|---|---|---|---|----|----|----|----|----|----|----|
| "IN" Number of inlets | 1 | 1 | 2 | 2 | 3 | 3 | 4 | 4 | 5  | 5  | 6  | 6  | 7  | 7  | 8  |

Flow divider with independent phase correction and anticavitation valves for each element

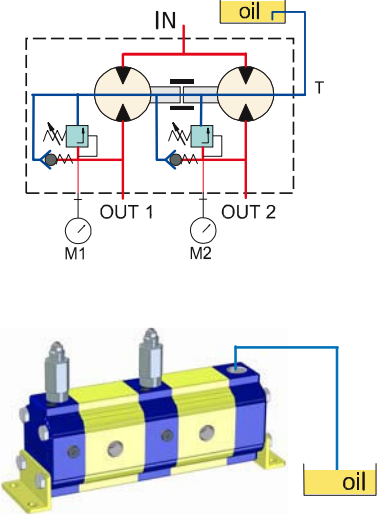
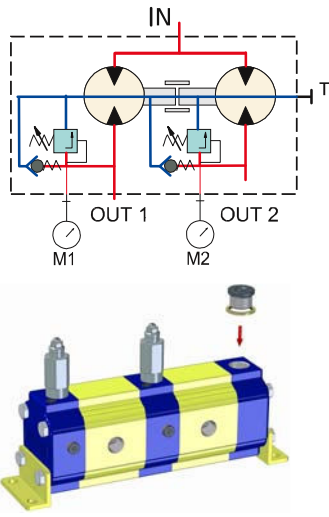
| EXTERNAL DRAIN<br><i>STANDARD SETUP</i>  | INTERNAL DRAIN  |
|--|---|
| <p>For the correct functioning of the flow divider, it has to be installed <i>under the oil level</i>. The drain tube has to pick up under the oil level and it has not to aspire air.</p> | <p>To predispose the divider to the internal drain, plug the 3/4" G drain port ( T )</p> <p>Note: with this configuration the function of anticavitation valves is annulled</p> |
|   |    |

In table 1 the functioning range of single flow divider elements is indicated .

The higher is the feeding capacity ( q ), the higher is the precision of flow division, but in opposition there are losses of loading and higher noise. Therefore we suggest to feed the elements with capacities equal or a few superior to the ones indicated in the column "RECOMMENDED".

It's important remember to verify the capacities even in phase of flow reunion.

The pressures indicated are to be considered as maximum of functioning, the flow divider is able to bear peaks of pressure 20% superior.

How to calculate the "Li" and "Lt" measures of flow dividers:

From table 2 it is possible to obtain the "Li" measure for flow dividers up to 16 elements with equal displacements; for flow dividers with different elements or with more than 16 elements the "Li" and "Lt" measure have to be calculated by the following formula:

$$Li = [(n-1) \times 44] + 124 + (A1 + A2 + A3 + \dots)$$

$$124 = 62 + 62$$

n = Number of elements of flow divider

A1 ... An = heights of elements of flow divider

$$Lt = Li + 24$$

$$24 = 12 + 12$$

EXAMPLE: To obtain the measures Li and Lt of a flow divider with three elements (n=3), RV-2V 19 + 11 + 9

Distance between fixing hole centres

$$Li = [(3-1) \times 44] + 124 + 72 + 58 + 54 = 396 \text{ mm}$$

Total Length

$$Lt = 396 + 24 = 420 \text{ mm}$$

In table 3 the number of inlets in function of the number of elements are indicated .

For flow dividers with many inlets, as they are all communicating it is even possible to use only one of them, by plugging the other ones. We suggest to use at least one 3/4" BSP inlet every 80 l/min capacity and at least one 1" BSP inlet every 120 l/min capacity

To obtain errors of division inferior to 3% there must be no difference of pressure between the elements superior to 30 bar. To obtain high precisions the respect of the following parameters is also important:

- Environment temperature: -10°C ÷ +60°C                      Oil temperature: +30°C ÷ +60°C
- Hydraulic oil based on hlp, hv (din 51524) minerals      Oil Viscosity 20 ÷ 40 cSt
- Oil filtering 10 ÷ 25 μ