

XV-0U COURBES CARACTERISTIQUE DE DEBIT

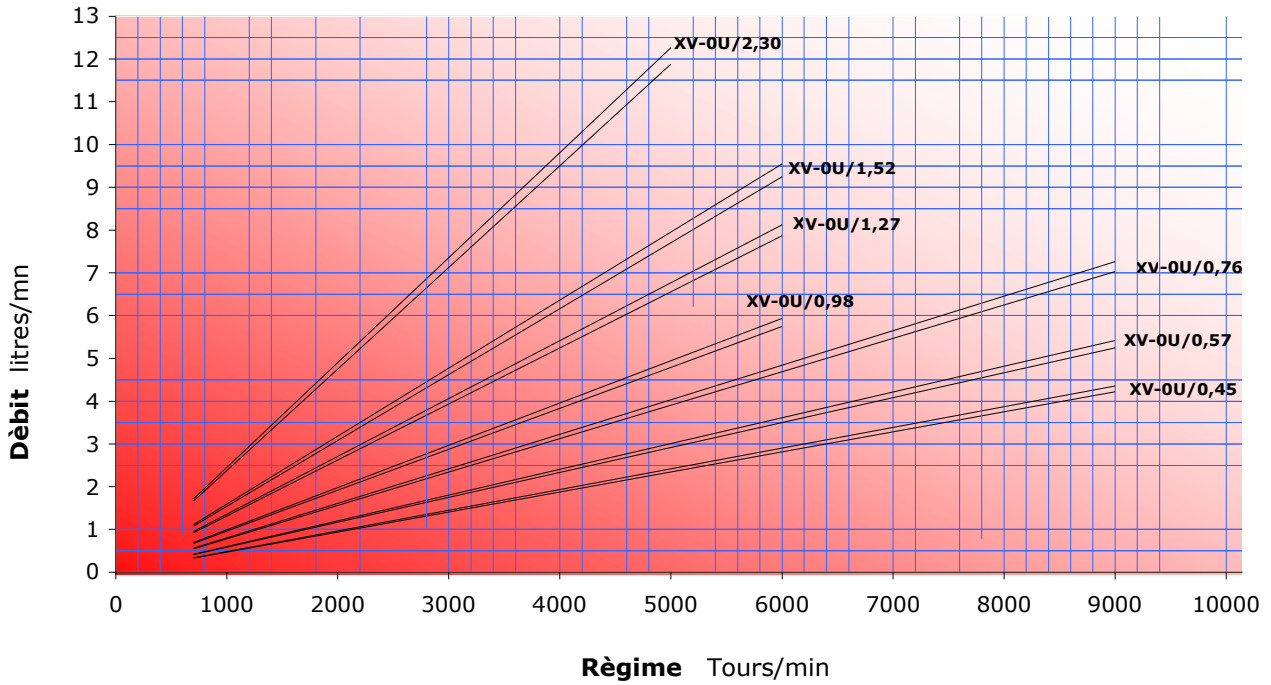

XV-0U COUPLE MOTEURS

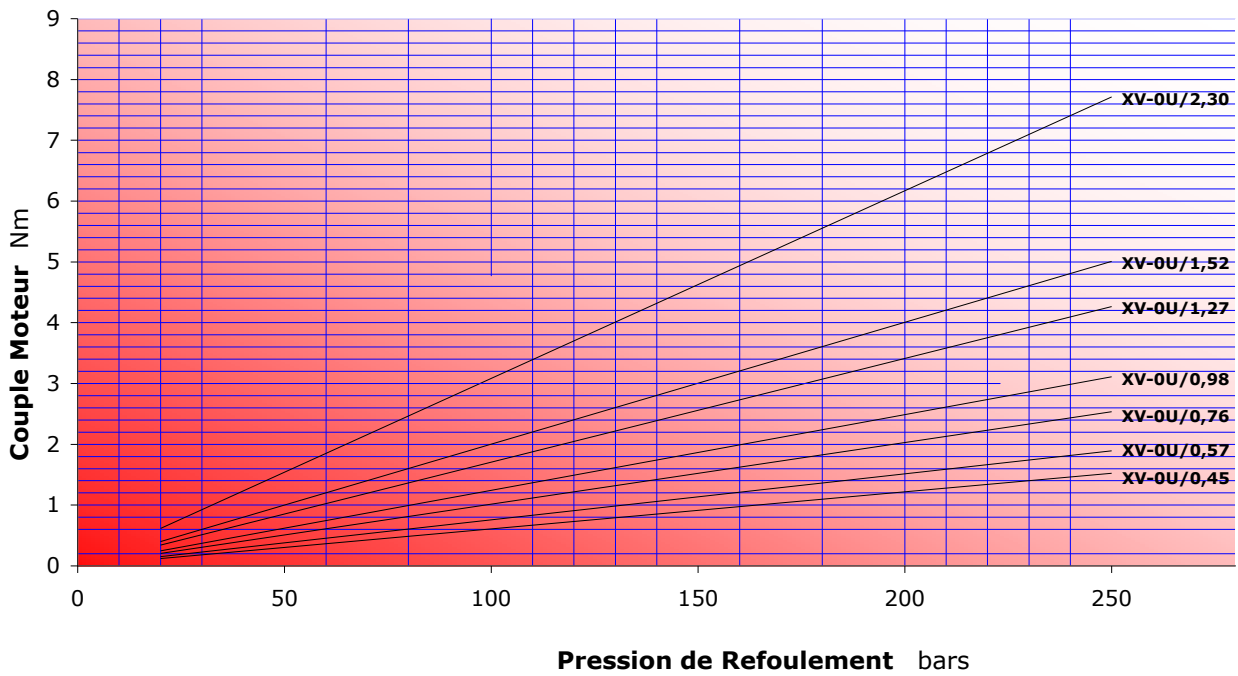

XV0-U avec FLASQUE ø22 STD , BH-HY (ref. de XU-001 a XU-017)

Pour modifier le sens de rotation de la moteur XV- 1U on utilise le même flasque avant et il n'est pas nécessaire de le changer.
 Pendant les opérations de démontage et de remontage de la moteur, veiller à ne pas faire sortir les garnitures et les joints anti-extrusion de leur logement, et à ne pas introduire dans la moteur de corps étrangers tels que des copeaux ou de la saleté en général.

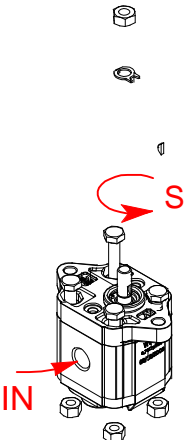
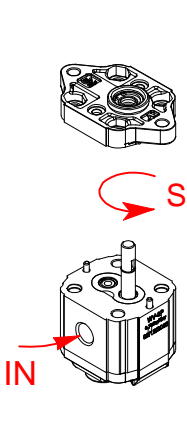
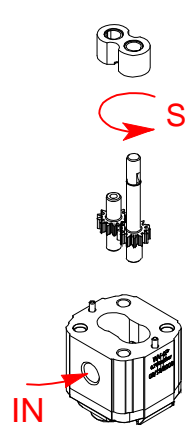
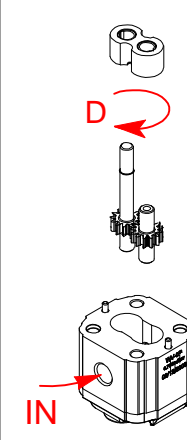
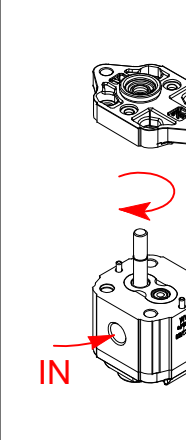
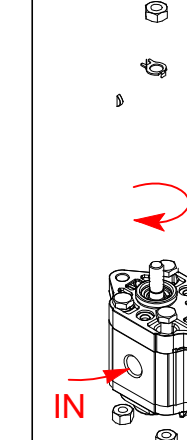
FLASQUE ø22 (rif. de XU- 001 à: XU- 021)					
					
Enlever de l'arbre la clavette, l'écrou et la rondelle. Dévisser et enlever les vis de fixation.	Enlever la flasque avant.	Enlever les engrenages et la bague supérieure. Attention !! La bague ne doit pas être tournée.	Inverser la position de l'arbre menant avec celle du conducteur. Attention !! Le corps et le couvercle ne doivent pas être tournés. Comme référence, se servir du repère sur le corps.	Remonter la flasque avant précédemment démonté en veillant à nettoyer les surfaces de contact corps-base.	Remonter les vis et serrer les écrous avec un couple de 11,7 Nm à 13,7 Nm. Après avoir terminé l'opération, vérifier que l'arbre tourne.
Note : avec ce système de changement de rotation, les trous d'entrée (IN) et e sortie (OUT) restent toujours les mêmes.					

moteur unidirectionnel - série XV



MOTEUR STANDARD

FLASQUE AVANT Ø22 - ARBRE CYLINDRIQUE

X	0	U	06	02	A	B	B	A
Série	X	série XV						
Groupe	0	groupe 0						
Catégorie	U	moteur unidirectionnel						
Cylindrée	06	0.76						
Flasque avant	02	Ø22 rotation à droite						
Arbre	A	Cl001 - Cylindrique ø7 - M7x1 - clavette épaisseur 2						
Corps	IN	B aspiration - 1/4" GAS						
	OUT	B refoulement - 1/4" GAS						
Couvercle	A	standard						

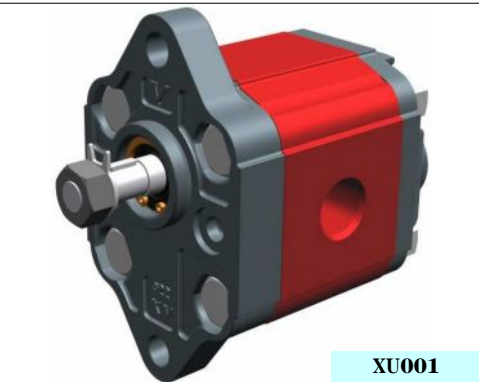

XU001

Tableau des données techniques											
TYPE	Cylindrée cm ³ /tour	Pression Max.		CODE							
		P1 bar	P3 bar	Rotation à gauche		Rotation à droite					
XV-OU/0.45	0,45	220	280	X	0	U	04 01 A B B A	X	0	U	04 02 A B B A
XV-OU/0.57	0,56	220	280	X	0	U	05 01 A B B A	X	0	U	05 02 A B B A
XV-OU/0.76	0,75	200	260	X	0	U	06 01 A B B A	X	0	U	06 02 A B B A
XV-OU/0.98	0,92	200	260	X	0	U	07 01 A B B A	X	0	U	07 02 A B B A
XV-OU/1.27	1,26	200	260	X	0	U	09 01 A B B A	X	0	U	09 02 A B B A
XV-OU/1.52	1,48	200	260	X	0	U	11 01 A B B A	X	0	U	11 02 A B B A
XV-OU/2.30	2,28	160	190	X	0	U	13 01 A B B A	X	0	U	13 02 A B B A

P1) Pression max de service - P3) Pression max de pointe

Pour applications lourdes il est conseillé de vérifier le couple admissible de l'arbre



Tableau des dimensions						
TYPE	Poids	A	B	C	D	D
	kg	mm	mm	mm	IN	OUT
XV-OU/0.45	0,420	58,0	27,3	49,0	1/4" BSPP	1/4" BSPP
XV-OU/0.57	0,430	59,0	27,8	50,0	1/4" BSPP	1/4" BSPP
XV-OU/0.76	0,440	60,5	28,5	51,5	1/4" BSPP	1/4" BSPP
XV-OU/0.98	0,460	62,0	29,3	53,0	1/4" BSPP	1/4" BSPP
XV-OU/1.27	0,480	64,5	30,5	55,5	1/4" BSPP	1/4" BSPP
XV-OU/1.52	0,500	66,5	31,5	57,5	1/4" BSPP	1/4" BSPP
XV-OU/2.30	0,560	72,5	34,5	63,5	1/4" BSPP	1/4" BSPP



07/12/04 XOP0602ABBA#F

T.1 = 11.7±13.7 [Nm] - couple de serrage vis M6

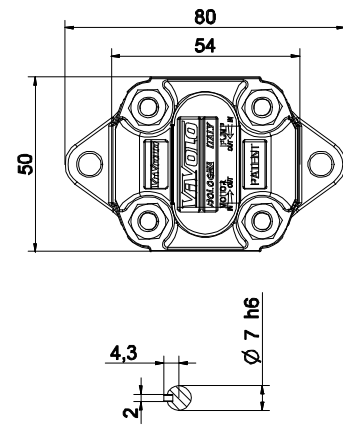
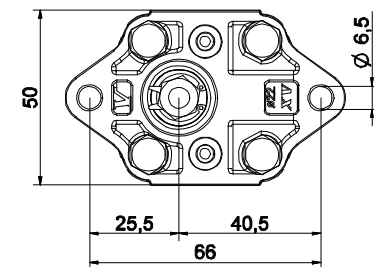
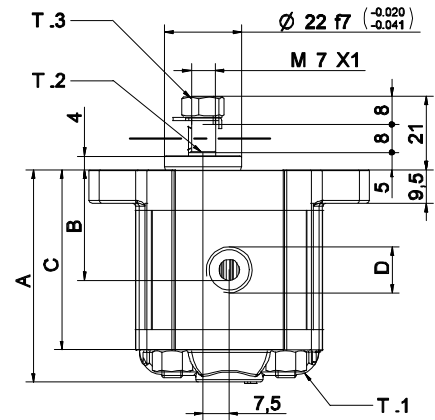
T.3 = 11.5 [Nm] - couple de serrage - clé 11

T.2 = 2.1 [Nm] - couple admissible de l'arbre (N.B. Pour le choix de l'arbre, vérifier toujours le couple admissible).

FLASQUE AVANT ø22 Standard

FLASQUE AVANT ø22 Standard			
Rotation à gauche		Rotation à droite	
	01		02
	03		04
	05		06
	07		08

Arbre			
CI001 - Cylindrique T.2 = 2.1 [Nm]	A	CF001 - Queue fraisée T.2 = 9.2 [Nm]	B
CF005 - Queue fraisée T.2 = 8.4 [Nm]	F	CO001 - Conique	E

Couvercle			
Rotation à gauche		Rotation à droite	
			A
			B
			C
			D
			N
Drainage intérieur			
			O
Drainage extérieur			

Cylindrée	
TYPE	CODE
XV-OU/0.45	04
XV-OU/0.57	05
XV-OU/0.76	06
XV-OU/0.98	07
XV-OU/1.27	09
XV-OU/1.52	11
XV-OU/2.30	13

Corps standard				
Cylindrée	cm ³ /tour	Filetages standard		
		B - B	Z - B	Z - Z
0.17		B - B	Z - B	Z - Z
0.25		B - B	Z - B	Z - Z
0.45		B - B	Z - B	Z - Z
0.57		B - B	Z - B	Z - Z
0.76		B - B	Z - B	Z - Z
0.98		B - B	Z - B	Z - Z
1.27		B - B	Z - B	Z - Z
1.52		B - B	Z - B	Z - Z
2.30		B - B	Z - B	Z - Z

Tableau des combinaisons des bridages et filetages standard disponibles en magasin

Corps (filetages et bridages)																
	A		B		C		D		E	F		G		H	I	Z
	H		I	Corps Renfermé		Z										

moteur unidirectionnel - série XV

XV-OU

MOTEUR TYPE "BH"

FLASQUE AVANT Ø22 MODELE - ARBRE QUEUE FRAISEE

X 0 U 06 12 B B B A

Série	X	série XV
Groupe	0	groupe 0
Catégorie	U	moteur unidirectionnel
Cylindrée	06	0.76
Flasque avant	12	Ø22 BH rotation à droite
Arbre	B	CF001 - Queue fraisée ø7 - épaisseur 5
Corps	IN	B aspiration - 1/4" GAS
	OUT	B refoulement - 1/4" GAS
Couvercle	A	standard



XU012

Tableau des données techniques

TYPE	Cylindrée cm ³ /tour	Pression Max.		CODE	
		P1 bar	P3 bar	Rotation à gauche	Rotation à droite
XV-OU/0.45	0,45	220	280	X 0 U 04 11 B B B A	X 0 U 04 12 B B B A
XV-OU/0.57	0,56	220	280	X 0 U 05 11 B B B A	X 0 U 05 12 B B B A
XV-OU/0.76	0,75	200	260	X 0 U 06 11 B B B A	X 0 U 06 12 B B B A
XV-OU/0.98	0,92	200	260	X 0 U 07 11 B B B A	X 0 U 07 12 B B B A
XV-OU/1.27	1,26	200	260	X 0 U 09 11 B B B A	X 0 U 09 12 B B B A
XV-OU/1.52	1,48	200	260	X 0 U 11 11 B B B A	X 0 U 11 12 B B B A
XV-OU/2.30	2,28	160	190	X 0 U 13 11 B B B A	X 0 U 13 12 B B B A

P1) Pression max de service - P3) Pression max de pointe

Pour applications lourdes il est conseillé de vérifier le couple admissible de l'arbre



Tableau des dimensions

TYPE	Poids	A	B	C	D	D
	kg	mm	mm	mm	IN	OUT
XV-OU/0.45	0,420	58,0	27,3	49,0	1/4" BSPP	1/4" BSPP
XV-OU/0.57	0,430	59,0	27,8	50,0	1/4" BSPP	1/4" BSPP
XV-OU/0.76	0,440	60,5	28,5	51,5	1/4" BSPP	1/4" BSPP
XV-OU/0.98	0,460	62,0	29,3	53,0	1/4" BSPP	1/4" BSPP
XV-OU/1.27	0,480	64,5	30,5	55,5	1/4" BSPP	1/4" BSPP
XV-OU/1.52	0,500	66,5	31,5	57,5	1/4" BSPP	1/4" BSPP
XV-OU/2.30	0,560	72,5	34,5	63,5	1/4" BSPP	1/4" BSPP

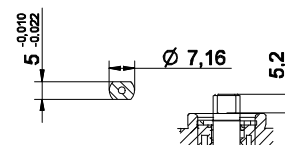
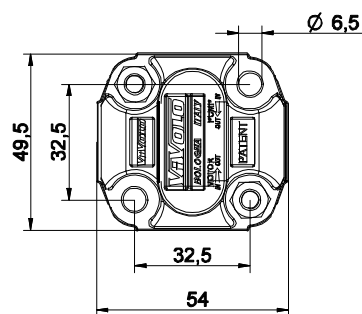
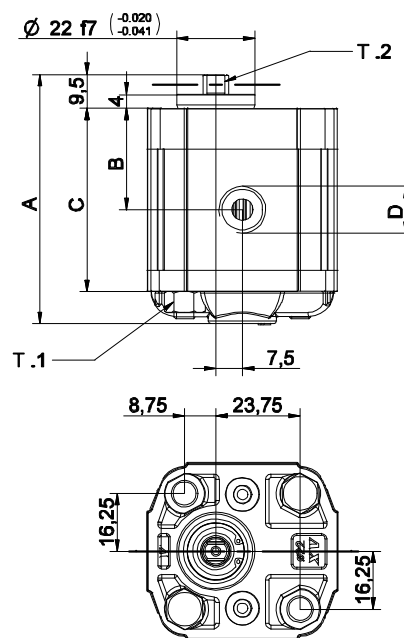

07/12/04 X0P0612888A.dft

T.1 = 11.7÷13.7 [Nm] - couple de serrage vis M6

T.2 = 9.2 [Nm] - couple admissible de l'arbre (N.B. Pour le choix de l'arbre, vérifier toujours le couple admissible).

FLASQUE AVANT ø22 - "BH" gabarié

FLASQUE AVANT ø22 - "BH" gabarié				Arbre				Couvercle					
Rotation à gauche		Rotation à droite						Rotation à gauche		Rotation à droite			
	11		12	Cl001 - Cylindrique T.2 = 2.1 [Nm]	A	CF001 - Queue fraisée T.2 = 9.2 [Nm]	B					A	
	13		14	CF005 - Queue fraisée T.2 = 8.4 [Nm]	F	CO001 - Conique T.2 = 21.9 [Nm]	E					B	
	15		16									C	
	17		18									D	

Cylindrée	
TYPE	CODE
XV-OU/0.45	04
XV-OU/0.57	05
XV-OU/0.76	06
XV-OU/0.98	07
XV-OU/1.27	09
XV-OU/1.52	11
XV-OU/2.30	13

Corps standard				
Cylindrée	cm ³ /tour	Filetages standard		
		B - B	Z - B	Z - Z
0.17		B - B	Z - B	Z - Z
0.25		B - B	Z - B	Z - Z
0.45		B - B	Z - B	Z - Z
0.57		B - B	Z - B	Z - Z
0.76		B - B	Z - B	Z - Z
0.98		B - B	Z - B	Z - Z
1.27		B - B	Z - B	Z - Z
1.52		B - B	Z - B	Z - Z
2.30		B - B	Z - B	Z - Z

Tableau des combinaisons des bridages et filetages standard disponibles en magasin

	N
Drainage intérieur	
	O
Drainage extérieur	

Corps (filetages et bridages)													
	A		B		C		D		E		F		G
	H		I	Corps Renfermé	Z								

moteur unidirectionnel - série XV



MOTEUR TYPE "HY"

FLASQUE AVANT Ø22 MODELE - ARBRE QUEUE FRAISEE

X	0	U	06	22	B	B	B	A
Série	X	série XV						
Groupe	0	groupe 0						
Catégorie	U	moteur unidirectionnel						
Cylindrée	06	0.76						
Flasque avant	22	Ø22 HY rotation à droite						
Arbre	B	CF001 - Queue fraisée ø7 - épaisseur 5						
Corps	IN	B aspiration - 1/4" GAS						
	OUT	B refoulement - 1/4" GAS						
Couvercle	A	standard						

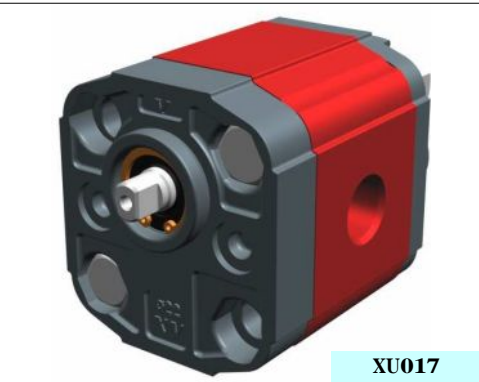

XU017

Tableau des données techniques																			
TYPE	Cylindrée	Pression Max.		CODE															
		cm³/tour	P1 bar	P3 bar	Rotation à gauche		Rotation à droite												
XV-OU/0.45	0,45	220	280	X	0	U	04 21	B	B	B	A	X	0	U	04 22	B	B	B	A
XV-OU/0.57	0,56	220	280	X	0	U	05 21	B	B	B	A	X	0	U	05 22	B	B	B	A
XV-OU/0.76	0,75	200	260	X	0	U	06 21	B	B	B	A	X	0	U	06 22	B	B	B	A
XV-OU/0.98	0,92	200	260	X	0	U	07 21	B	B	B	A	X	0	U	07 22	B	B	B	A
XV-OU/1.27	1,26	200	260	X	0	U	09 21	B	B	B	A	X	0	U	09 22	B	B	B	A
XV-OU/1.52	1,48	200	260	X	0	U	11 21	B	B	B	A	X	0	U	11 22	B	B	B	A
XV-OU/2.30	2,28	160	190	X	0	U	13 21	B	B	B	A	X	0	U	13 22	B	B	B	A

P1) Pression max de service - P3) Pression max de pointe

Pour applications lourdes il est conseillé de vérifier le couple admissible de l'arbre



Tableau des dimensions						
TYPE	Poids	A	B	C	D	D
	kg	mm	mm	mm	IN	OUT
XV-OU/0.45	0,420	58,0	27,3	49,0	1/4" BSPP	1/4" BSPP
XV-OU/0.57	0,430	59,0	27,8	50,0	1/4" BSPP	1/4" BSPP
XV-OU/0.76	0,440	60,5	28,5	51,5	1/4" BSPP	1/4" BSPP
XV-OU/0.98	0,460	62,0	29,3	53,0	1/4" BSPP	1/4" BSPP
XV-OU/1.27	0,480	64,5	30,5	55,5	1/4" BSPP	1/4" BSPP
XV-OU/1.52	0,500	66,5	31,5	57,5	1/4" BSPP	1/4" BSPP
XV-OU/2.30	0,560	72,5	34,5	63,5	1/4" BSPP	1/4" BSPP

T.1 = 11.7±13.7 [Nm] - couple de serrage vis M6

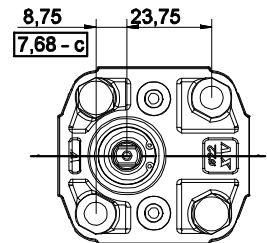
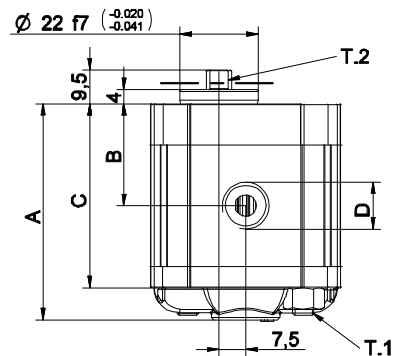
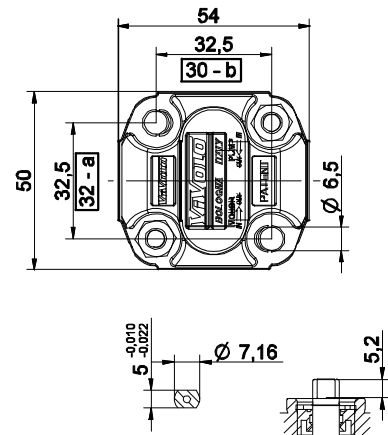

T.2 = 9.2 [Nm] - couple admissible de l'arbre (N.B. Pour le choix de l'arbre, vérifier toujours le couple admissible).

NOTE: Ce type de pompe est aussi interchangeable avec entre-axes de fixation in M5 (voir cotes a, b, c).



07/12/04 X0P062288A.dft

Planche des variantes

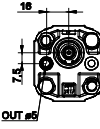
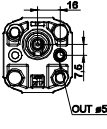
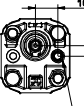
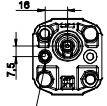
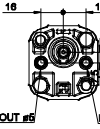
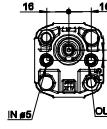
FLASQUE AVANT ø22 - "HY" gabarié

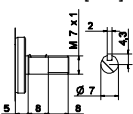
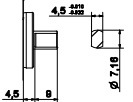
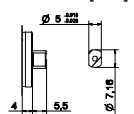
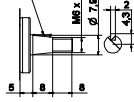
FLASQUE AVANT ø22 - "HY" gabarié			
Rotation à gauche		Rotation à droite	
	21		22
	23		24
	25		26
	27		28

Arbre			
CI001 - Cylindrique T.2 = 2.1 [Nm]		A	B
			
CF005 - Queue fraisée T.2 = 8.4 [Nm]		F	E
			
CF001 - Queue fraisée T.2 = 9.2 [Nm]		A	B
			
CO001 - Conique T.2 = 21.9 [Nm]		F	E
			

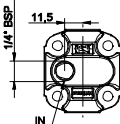
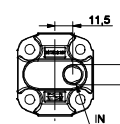
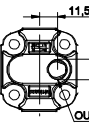
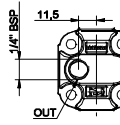
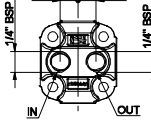
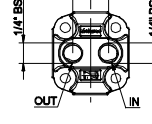
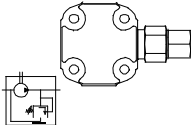
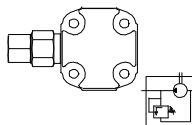
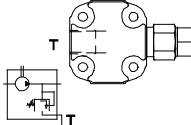
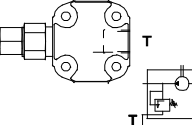
Couvercle			
Rotation à gauche		Rotation à droite	
			A
			B
			C
			D
			N
Drainage intérieur			
			O
Drainage extérieur			

Cylindrée	
TYPE	CODE
XV-OU/0.45	04
XV-OU/0.57	05
XV-OU/0.76	06
XV-OU/0.98	07
XV-OU/1.27	09
XV-OU/1.52	11
XV-OU/2.30	13

Corps standard				
Cylindrée	cm3/tour	Filetages standard		
		0.17	B - B	Z - B
0.25	B - B	Z - B	Z - Z	
0.45	B - B	Z - B	Z - Z	
0.57	B - B	Z - B	Z - Z	
0.76	B - B	Z - B	Z - Z	
0.98	B - B	Z - B	Z - Z	
1.27	B - B	Z - B	Z - Z	
1.52	B - B	Z - B	Z - Z	
2.30	B - B	Z - B	Z - Z	

Tableau des combinaisons des bridages et filetages standard disponibles en magasin

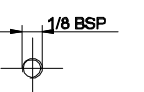
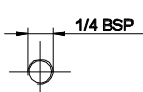
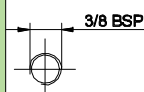
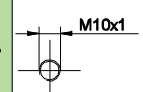
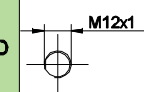
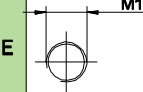
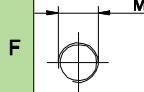
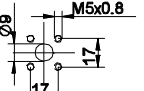
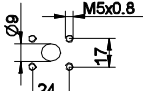
Corps (filetages et bridages)													
	A		B		C		D		E		F		G
	H		I	Corps Renfermé		Z							