

MOTEURS - HYDRAULIC MOTORS

MPR (MR)



MOTEUR "M+S HYDRAULIC"
"M+S HYDRAULIC" MOTOR

ARBRE CYLINDRIQUE Ø25
PARALLEL SHAFT Ø25

BRIDE "SAE A" - 2 TROUS
"SAE A" FLANGE - 2 HOLES

Standard: ALIMENTATIONS LATÉRALES - SIDE PORTS

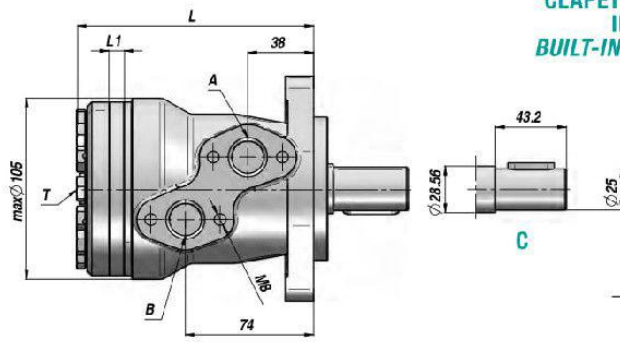
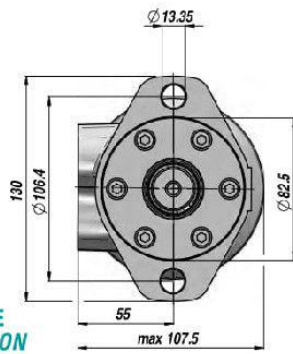

CLAPET ANTI-RETOUR
INTÉGRE
BUILT-IN CHECK VALVES

PREDISPOSITION POUR DRAINAGE
MACHINED FOR DRAIN CONNECTION

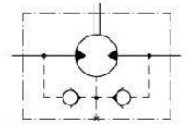

Code Code	Type Type	cm ³ /tr cm ³ /rev	n. Max tours/min rpm	M Max daNm	Q MAX l/min	P MAX bar			A - B	T	L	L1	kg
						Chute Drop Δp	Entrée Inlet	Retour Return					
TRAVAIL EN CONTINU - CONTINUOUS WORK													
MSR050NC25	MPR 50 C	51.5	775	10.0	40	140	175	175 *	1/2"	1/4"	138.0	9.0	6.80
MSR080NC25	MPR 80 C	80.3	750	20.0	60	175	175	175 *					
MSR100NC25	MPR 100 C	99.8	600	24.0	60	175	175	175 *					
MSR125NC25	MPR 125 C	125.7	475	30.0	60	175	175	175 *					
MSR160NC25	MPR 160 C	159.6	375	39.0	60	175	175	175 *					
MSR200NC25	MPR 200 C	199.8	300	38.5	60	140	175	175 *					
MSR250NC25	MPR 250 C	250.1	240	39.0	60	110	175	175 *					
MSR315NC25	MPR 315 C	315.7	190	36.0	60	85	175	175 *					
MSR400NC25	MPR 400 C	397.0	150	38.0	60	65	175	175 *	198.0	69.4	9.80		

* = AVEC DRAINAGE - WITH DRAIN

OPTION

CO

SH

K

CB

KB

OPTION

Q: (Square Mount)

OPTION

**E: ALIMENTATIONS ARRIÈRES
REAR PORTS**

**PRESSION MAXI EN RETOUR SANS DRAINAGE
MAX. RETURN PRESSURE WITHOUT DRAIN**

1: Low pressure shaft seal
2: Standard seal for "...B" shaft
3: High pressure shaft seal ("D" type)

— - - - - continuous operations
- - - - - intermittent operations

VERSIONS SPECIALES - SPECIAL VERSIONS

D: joint d'arbre - shaft seal: max 150 bar

N/D: arbre renforcé - with needle bearings

W: moto-rue - wheel mount

**CHARGES ADMISSIBLES SUR L'ARBRE
PERMISSIBLE SHAFT LOADS**

Shaft: "C-CO"

Oval mount: Pa max = 150 daN

Square mount: Pa max = 200 daN

With Needle bearings: "N"

1. Max. radial shaft load
2. n = 50 rpm
3. n = 200 rpm
4. n = 800 rpm

HYDRAULIC MOTORS MR



APPLICATION

- » Conveyors
- » Feeding mechanism of robots and manipulators
- » Metal working machines
- » Textile machines
- » Agricultural machines
- » Food industries
- » Grass cutting machinery etc.

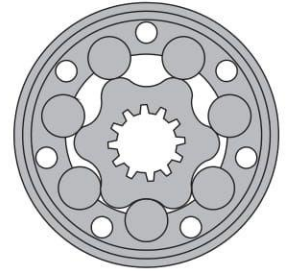

CONTENTS

Specification data29÷30
 Function diagrams31÷39
 Dimensions and mounting 40÷41
 Shaft extensions 28
 Permissible shaft loads 29
 Permissible shaft Seal Pressure ... 30
 Order code 42

OPTIONS

- » Model - Spool valve, roll-gerotor
- » Flange mount
- » Motor with needle bearing
- » Side and rear ports
- » Shafts - straight, splined and tapered
- » Shaft seal for high and low pressure
- » Metric and BSPP ports
- » Speed sensing
- » Other special features

GENERAL

Max. Displacement, cm ³ /rev [in ³ /rev]	397 [24.4]
Max. Speed, [RPM]	970
Max. Torque, daNm [lb-in]	cont.: 61 [5400] int.: 69 [6100]
Max. Output, kW [HP]	15 [20.1]
Max. Pressure Drop, bar [PSI]	cont.: 175 [2540] int.: 200 [2900]
Max. Oil Flow, lpm [GPM]	75 [20]
Min. Speed, [RPM]	10
Pressure fluid	Mineral based- HLP(DIN 51524) or HM(ISO 6743/4)
Temperature range, °C [°F]	-40÷140 [-40÷284]
Optimal Viscosity range, mm ² /s [SUS]	20÷75 [98÷347]
Filtration	ISO code 20/16 (Min. recommended fluid filtration of 25 microns)

Oil flow in drain line

Pressure drop bar [PSI]	Viscosity mm ² /s [SUS]	Oil flow in drain line lpm [GPM]
100 [1450]	20 [98]	2,5 [.660]
	35 [164]	1,8 [.476]
140 [2030]	20 [98]	3,5 [.925]
	35 [164]	2,8 [.740]

Pressure Losses

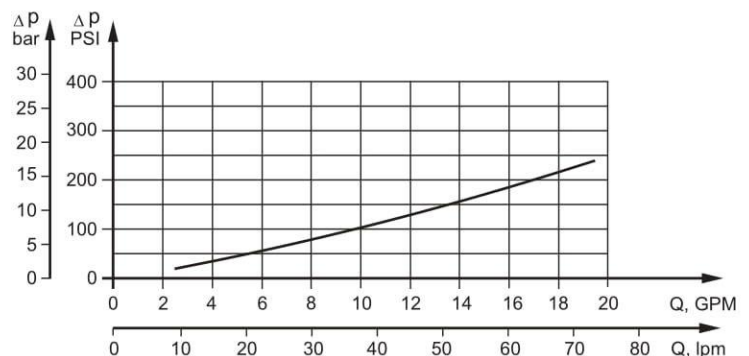

SPECIFICATION DATA

Specification Data for MR... motors with **C, CO, SH, K** and **SA** shafts.
($\varnothing 28,56$ sealing diameter)

Type		MR 50	MR 80	MR 100	MR 125	MR 160	MR 200	MR 250	MR 315	MR 400
Displacement, cm ³ /rev [in ³ /rev]		51,5 [3.14]	80,3 [4.90]	99,8 [6.09]	125,7 [7.67]	159,6 [9.74]	199,8 [12.19]	250,1 [15.26]	315,7 [19.26]	397 [24.4]
	Max. Speed, [RPM]									
	Cont.	775	750	600	475	375	300	240	190	150
	Int.*	970	940	750	600	470	375	300	240	190
Max. Torque daNm [in-lb]	Cont.	10 [900]	20 [1770]	24 [2125]	30 [2655]	39 [3450]	38,5[3410]	39 [3450]	36 [3185]	38 [3360]
	Int.*	13 [1150]	22 [1947]	28 [2480]	34 [3010]	43 [3805]	46 [4070]	47 [4160]	47 [4160]	47 [4160]
	Peak**	17 [1505]	27 [2390]	32 [2832]	37 [3275]	46 [4070]	56 [4960]	60 [5310]	61 [5400]	61 [5400]
Max. Output kW [HP]	Cont.	7 [9.5]	12,5 [17]	13 [17.4]	12,5[16.8]	11,5[15.4]	9 [12]	8 [10.7]	5 [6.7]	4,8 [6.4]
	Int.*	8,5 [11.9]	15 [20.1]	15 [20.1]	14,5[19.5]	14 [18.8]	12 [16.1]	9,5 [12.7]	8 [10.7]	6,8 [9.1]
Max. Pressure Drop bar [PSI]	Cont.	140[2030]	175[2540]	175[2540]	175[2540]	175[2540]	140[2030]	110[1600]	85 [1230]	65 [940]
	Int.*	175[2540]	200[2900]	200[2900]	200[2900]	200[2900]	175[2540]	140[2030]	115[1670]	90 [1300]
	Peak**	225[3260]	225[3260]	225[3260]	225[3260]	225[3260]	225[3260]	200[2900]	150[2175]	115[1670]
Max. Oil Flow lpm [GPM]	Cont.	40 [10.5]	60 [15.8]	60 [15.8]	60 [15.8]	60 [15.8]	60 [15.8]	60 [15.8]	60 [15.8]	60 [15.8]
	Int.*	50 [13.2]	75 [19.8]	75 [19.8]	75 [19.8]	75 [19.8]	75 [19.8]	75 [19.8]	75 [19.8]	75 [19.8]
Max. Inlet Pressure bar [PSI]	Cont.	175[2540]	175[2540]	175[2540]	175[2540]	175[2540]	175[2540]	175[2540]	175[2540]	175[2540]
	Int.*	200[2900]	200[2900]	200[2900]	200[2900]	200[2900]	200[2900]	200[2900]	200[2900]	200[2900]
	Peak**	225[3260]	225[3260]	225[3260]	225[3260]	225[3260]	225[3260]	225[3260]	225[3260]	225[3260]
Max. Return Pres- sure with Drain Line bar [PSI]	Cont.	175[2540]	175[2540]	175[2540]	175[2540]	175[2540]	175[2540]	175[2540]	175[2540]	175[2540]
	Int.*	200[2900]	200[2900]	200[2900]	200[2900]	200[2900]	200[2900]	200[2900]	200[2900]	200[2900]
	Peak**	225[3260]	225[3260]	225[3260]	225[3260]	225[3260]	225[3260]	225[3260]	225[3260]	225[3260]
Max. Starting Pressure with Unloaded Shaft, bar [PSI]		10 [145]	10 [145]	10 [145]	9 [130]	7 [102]	5 [73]	4 [58]	3 [44]	3 [44]
Min. Starting Torque daNm [in-lb]	At max.press. drop Cont.	8 [710]	15 [1330]	20 [1770]	25 [2215]	32 [2832]	33 [2920]	31 [2740]	31,5[2875]	31,5[2875]
	At max.press. drop Int.*	10 [85]	17 [1505]	23 [2035]	28 [2480]	37 [3275]	40 [3540]	48 [4250]	58 [5220]	50 [4425]
Min. Speed***, [RPM]		10	10	10	10	10	10	10	10	10
Weight, kg [lb]	MR(F)	6,8 [15]	6,9 [15.2]	7,2 [15.9]	7,3 [16.1]	7,5 [15.2]	8 [17.6]	8,4 [18.5]	9,1 [20]	9,8 [21.6]
For rear ports: +0,650 [1.433]	MRQ(N)	6,2 [13.7]	6,3 [13.9]	6,6 [14.6]	6,8 [15]	7,2 [14.7]	7,6 [15.4]	7,8 [17.2]	8,6 [19]	9,3 [20.5]

* Intermittent operation: the permissible values may occur for max. 10% of every minute.

** Peak load: the permissible values may occur for max. 1% of every minute.

*** For speeds lower than given, consult factory or your regional manager.

- Intermittent speed and intermittent pressure must not occur simultaneously.
- Recommended filtration is per ISO cleanliness code 20/16. A nominal filtration of 25 micron or better.
- Recommend using a premium quality, anti-wear type mineral based hydraulic oil HLP(DIN51524) or HM (ISO 6743/4).
If using synthetic fluids consult the factory for alternative seal materials.
- Recommended minimum oil viscosity 13 mm²/s [70 SUS] at 50°C [122°F].
- Recommended maximum system operating temperature is 82°C [180°F].
- To assure optimum motor life fill with fluid prior to loading and run at moderate load and speed for 10-15 minutes.

SPECIFICATION DATA (continued)

Specification Data for MR... motors with CB, KB, OB and HB shafts.
(ø35 sealing diameter)

Type		MR 50	MR 80	MR 100	MR 125	MR 160	MR 200	MR 250	MR 315	MR 400
Displacement, cm ³ /rev [in ³ /rev]		51,5 [3.14]	80,3 [4.90]	99,8 [6.09]	125,7 [7.67]	159,6 [9.74]	199,8 [12.19]	250,1 [15.26]	315,7 [19.26]	397 [24.4]
	Max. Speed, [RPM]									
Max. Torque daNm [in-lb]	Cont.	775	750	600	475	375	300	240	190	150
	Int.*	970	940	750	600	470	375	300	240	190
Max. Output kW [HP]	Cont.	10 [900]	20 [1770]	24 [2125]	30 [2655]	39 [3450]	45 [4000]	54 [4780]	55 [4870]	61 [5400]
	Int.*	13 [1150]	22 [1947]	28 [2480]	34 [3010]	43 [3805]	50 [4425]	61 [5400]	69 [6110]	69 [6110]
	Peak**	17 [1505]	27 [2390]	32 [2832]	37 [3275]	46 [4070]	56 [4960]	71 [6280]	84 [7435]	87 [7700]
Max. Pressure Drop bar [PSI]	Cont.	7 [9.5]	12,5 [17]	13 [17.4]	12,5[16.8]	11,5[15.4]	11 [14.8]	10 [13.4]	9 [12]	7,8 [10.5]
	Int.*	8,5 [11.9]	15 [20.1]	15 [20.1]	14,5[19.5]	14 [18.8]	13 [17.4]	12 [16.1]	10 [13.4]	10,6[14.2]
	Peak**	140[2030]	175[2540]	175[2540]	175[2540]	175[2540]	175[2540]	175[2540]	135[1960]	110[1600]
Max. Oil Flow lpm [GPM]	Cont.	175[2540]	200[2900]	200[2900]	200[2900]	200[2900]	200[2900]	200[2900]	175[2540]	140[2030]
	Int.*	225[3260]	225[3260]	225[3260]	225[3260]	225[3260]	225[3260]	225[3260]	210[3045]	175[2540]
	Peak**	40 [10.5]	60 [15.8]	60 [15.8]	60 [15.8]	60 [15.8]	60 [15.8]	60 [15.8]	60 [15.8]	60 [15.8]
Max. Inlet Pressure bar [PSI]	Cont.	50 [13.2]	75 [19.8]	75 [19.8]	75 [19.8]	75 [19.8]	75 [19.8]	75 [19.8]	75 [19.8]	75 [19.8]
	Int.*	175[2540]	175[2540]	175[2540]	175[2540]	175[2540]	175[2540]	175[2540]	175[2540]	175[2540]
	Peak**	200[2900]	200[2900]	200[2900]	200[2900]	200[2900]	200[2900]	200[2900]	200[2900]	200[2900]
Max. Return Pres- sure with Drain Line bar [PSI]	Cont.	225[3260]	225[3260]	225[3260]	225[3260]	225[3260]	225[3260]	225[3260]	225[3260]	225[3260]
	Int.*	175[2540]	175[2540]	175[2540]	175[2540]	175[2540]	175[2540]	175[2540]	175[2540]	175[2540]
	Peak**	200[2900]	200[2900]	200[2900]	200[2900]	200[2900]	200[2900]	200[2900]	200[2900]	200[2900]
Max. Starting Pressure with Unloaded Shaft, bar [PSI]	Cont.	225[3260]	225[3260]	225[3260]	225[3260]	225[3260]	225[3260]	225[3260]	225[3260]	225[3260]
	Int.*	10 [145]	10 [145]	10 [145]	9 [130]	7 [102]	5 [73]	4 [58]	3 [44]	3 [44]
	Peak**									
Min. Starting Torque daNm [in-lb]	At max.press. drop Cont.	8 [710]	15 [1330]	20 [1770]	25 [2215]	32 [2832]	41 [3630]	50 [4425]	50 [4425]	50 [4425]
	At max.press. drop Int.*	10 [885]	17 [1505]	23 [2035]	28 [2480]	37 [3275]	46 [4070]	55 [4870]	66 [5840]	61 [5400]
Min. Speed***, [RPM]		10	10	10	10	10	10	10	10	10
Weight, kg [lb]										
For rear ports: +0,650 [1.433]		6,9 [15,2]	7 [15,4]	7,3 [16.1]	7,4 [16.3]	7,6 [15.4]	8,1 [18.9]	8,5 [18.7]	9,2 [20.3]	9,9 [21.8]

* Intermittent operation: the permissible values may occur for max. 10% of every minute.

** Peak load: the permissible values may occur for max. 1% of every minute.

*** For speeds lower than given, consult factory or your regional manager.

1. Intermittent speed and intermittent pressure must not occur simultaneously.
2. Recommended filtration is per ISO cleanliness code 20/16. A nominal filtration of 25 micron or better.
3. Recommend using a premium quality, anti-wear type mineral based hydraulic oil HLP(DIN51524) or HM (ISO 6743/4).
If using synthetic fluids consult the factory for alternative seal materials.
4. Recommended minimum oil viscosity 13 mm²/s [70 SUS] at 50°C [122°F].
5. Recommended maximum system operating temperature is 82°C [180°F].
6. To assure optimum motor life fill with fluid prior to loading and run at moderate load and speed for 10-15 minutes.

DIMENSIONS AND MOUNTING DATA

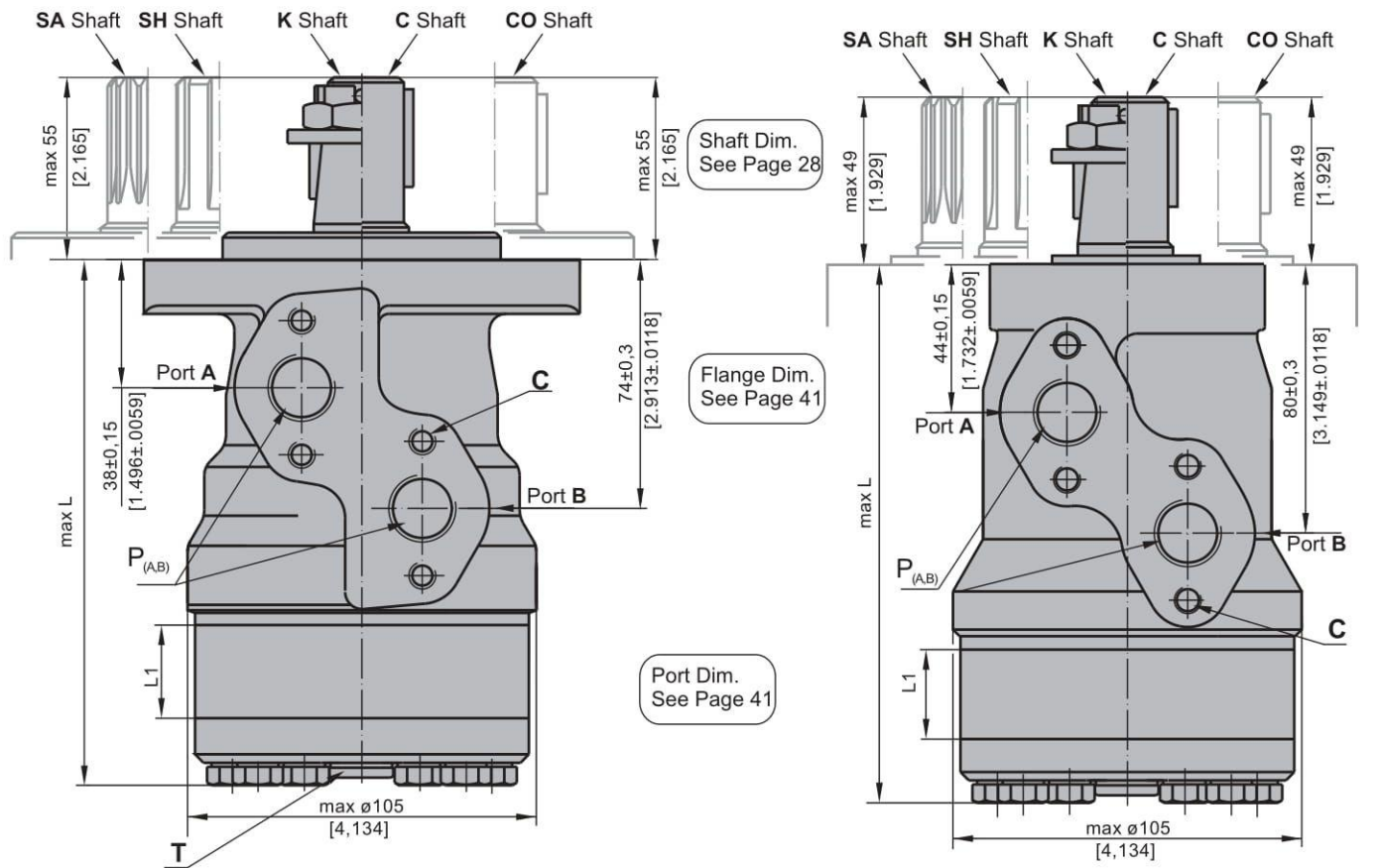

E Rear ports

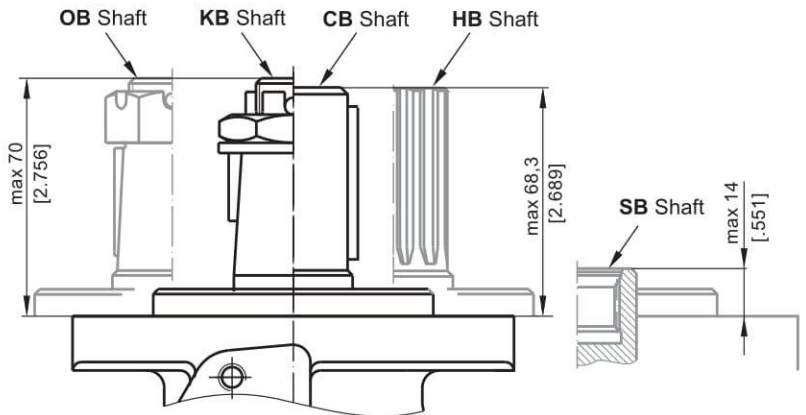
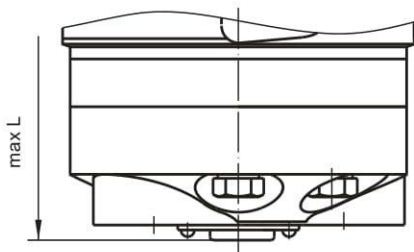

- C** : 4xM8 - 13 mm [.51 in] depth
- P_(A,B)**: 2xG1/2 or 2xM22x1,5 - 15 mm [.59 in] depth
- T** : G1/4 or M14x1,5 - 12 mm [.47 in] depth (plugged)

- Standard Rotation**
Viewed from Shaft End
Port A Pressurized - **CW**
Port B Pressurized - **CW**
- Reverse Rotation**
Viewed from Shaft End
Port A Pressurized - **CCW**
Port B Pressurized - **CW**

Type	L, mm [in]	Type	L, mm [in]	Type	L, mm [in]	Type	L, mm [in]	L ₁ , mm [in]
MR(F) 50	138,0 [5.43]	MRQ 50	143,5 [5.65]	MR(F)E 50	157,5 [6.20]	MRQE 50	163,5 [6.44]	9,0 [.35]
MR(F) 80	143,0 [5.63]	MRQ 80	148,5 [5.85]	MR(F)E 80	162,5 [6.40]	MRQE 80	168,5 [6.63]	14,0 [.55]
MR(F) 100	146,0 [5.75]	MRQ 100	152,0 [5.98]	MR(F)E 100	165,5 [6.52]	MRQE 100	171,5 [6.75]	17,4 [.69]
MR(F) 125	150,5 [5.93]	MRQ 125	156,5 [6.16]	MR(F)E 125	170,0 [6.69]	MRQE 125	176,0 [6.93]	21,8 [.86]
MR(F) 160	156,5 [6.16]	MRQ 160	162,5 [6.40]	MR(F)E 160	176,0 [6.93]	MRQE 160	182,0 [7.17]	27,8 [1.09]
MR(F) 200	163,5 [6.44]	MRQ 200	169,5 [6.67]	MR(F)E 200	183,0 [7.20]	MRQE 200	189,0 [7.44]	34,8 [1.37]
MR(F) 250	172,0 [6.77]	MRQ 250	179,0 [7.05]	MR(F)E 250	192,0 [7.56]	MRQE 250	198,0 [7.80]	43,5 [1.71]
MR(F) 315	183,0 [7.20]	MRQ 315	189,0 [7.44]	MR(F)E 315	204,0 [8.03]	MRQE 315	210,0 [8.27]	54,8 [2.16]
MR(F) 400	198,0 [7.80]	MRQ 400	204,0 [8.03]	MR(F)E 400	218,0 [8.58]	MRQE 400	224,0 [8.82]	69,4 [2.73]

MOUNTING

Oval Mount (2 Holes)

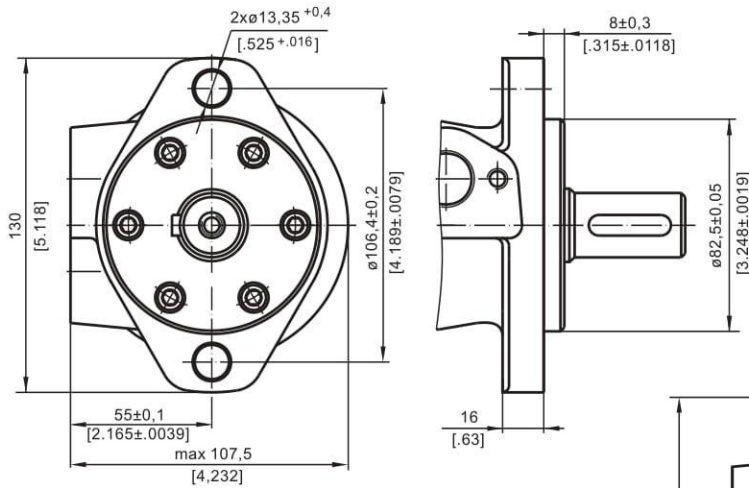

F - Oval Mount (4 Holes)

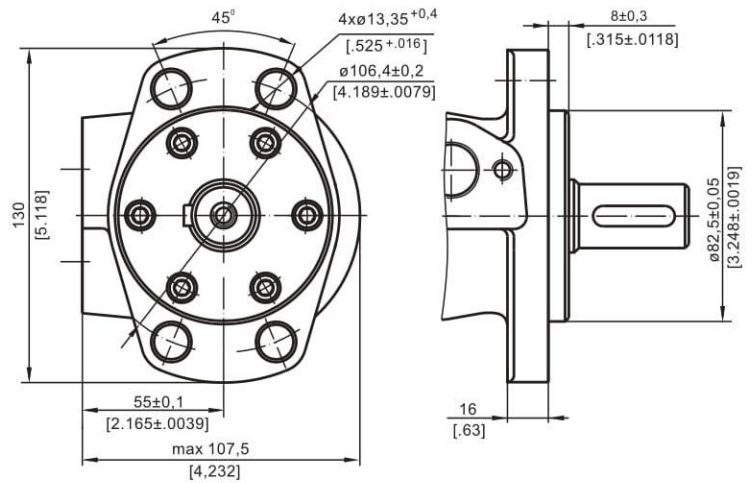

Q - Square Mount (4 Bolts)

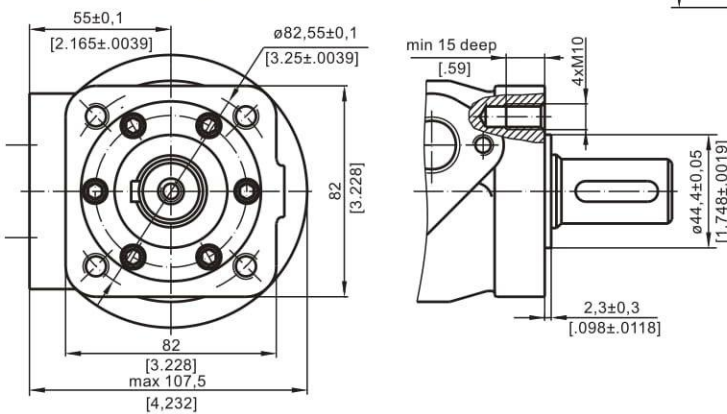

PORTS

Side Ports

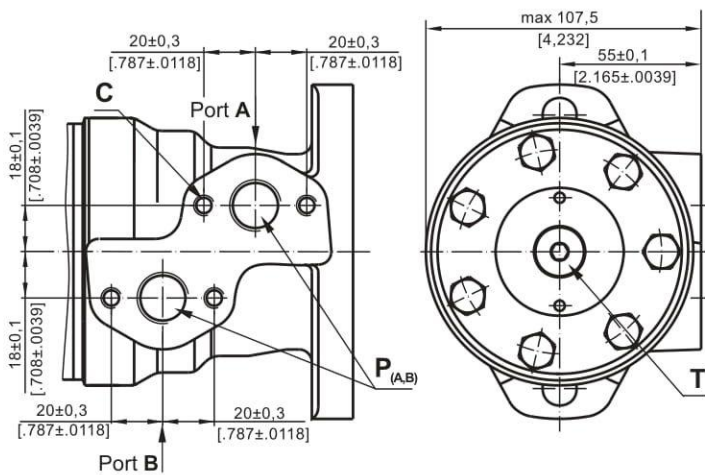

E Rear Ports

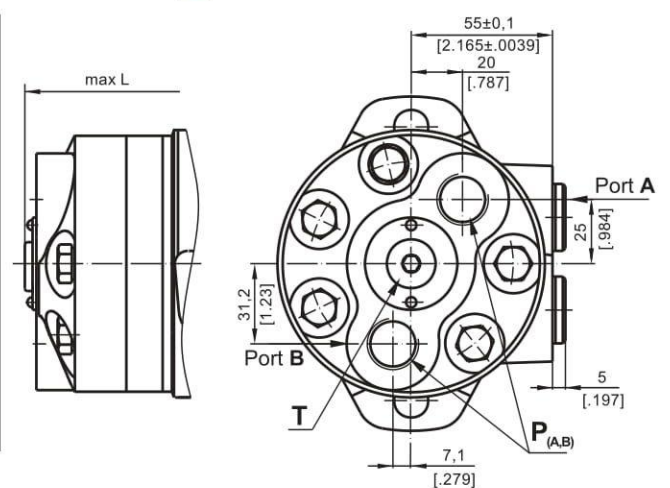

- C** : 4xM8 - 13 mm [.51 in] depth
- P_(A,B)** : 2xG1/2 or 2xM22x1,5 - 15 mm [.59 in] depth
- T** : G1/4 or M14x1,5 - 12 mm [.47 in] depth (plugged)

Standard Rotation
Viewed from Shaft End
Port A Pressurized - CW
Port B Pressurized - CCW

Reverse Rotation
Viewed from Shaft End
Port A Pressurized - CCW
Port B Pressurized - CW

SHAFT EXTENSIONS FOR MP AND MR MOTORS

C - $\varnothing 25$ straight, Parallel key A8x7x32 DIN 6885
Max. Torque 34 daNm [3010 lb-in]

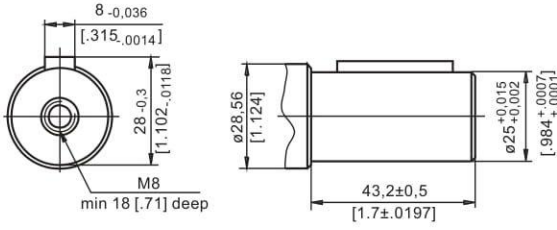

CB - $\varnothing 32$ straight, Parallel key A10x8x45 DIN 6885
Max. Torque 77 daNm [6815 lb-in]

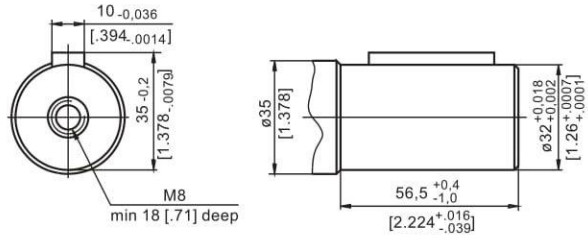

CO - $\varnothing 1"$ straight, Parallel key $1/4"x1/4"x1 1/4"$ BS46
Max. Torque 34 daNm [3010 lb-in]

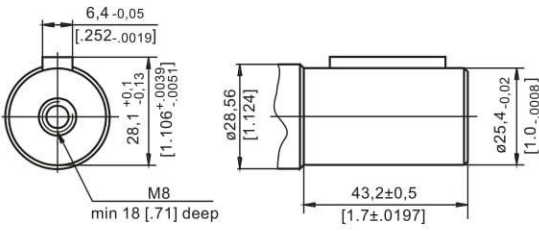

SB - splined A25x22xH10 DIN 5482
Max. Torque 34 daNm [3010 lb-in]

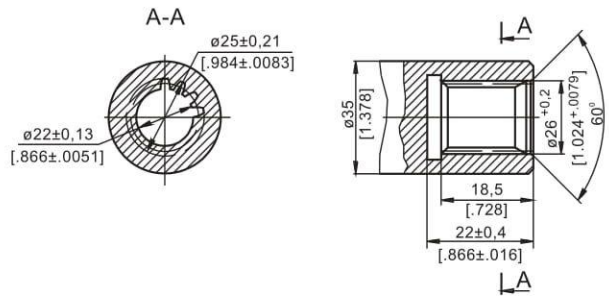

SH - splined, BS 2059 (SAE 6B)
Max. Torque 40 daNm [3540 lb-in]

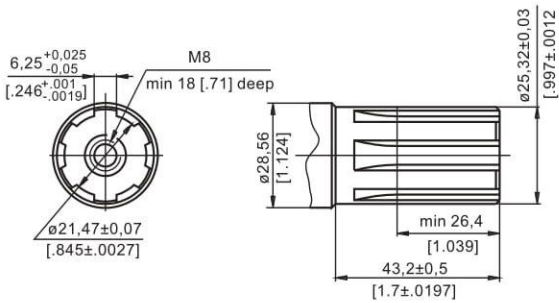

KB - tapered 1:10, Parallel key B6x6x20 DIN 6885
Max. Torque 77 daNm [6815 lb-in]

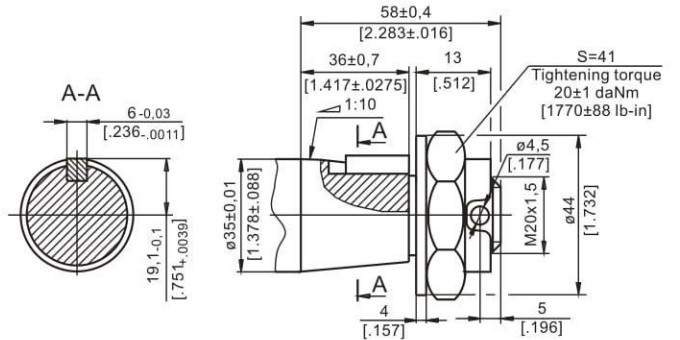

K - tapered 1:10, Parallel key B5x5x14 DIN 6885
Max. Torque 40 daNm [3540 lb-in]

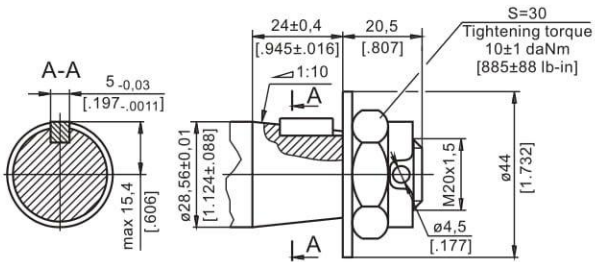

OB - tapered 1:8 SAEJ 501, Parallel key $5/16"x5/16"x1 1/4"$ BS46
Max. Torque 77 daNm [6815 lb-in]

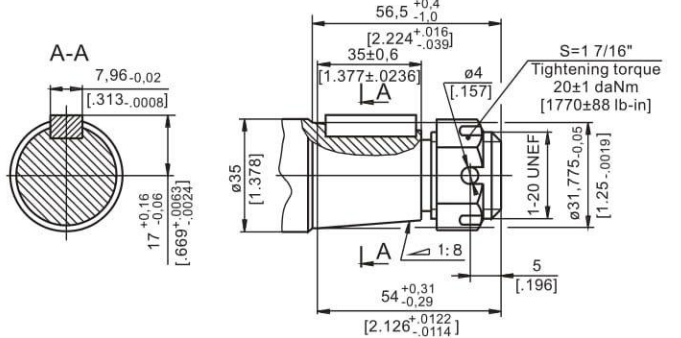

SA - splined, B25x22h9 DIN 5482
Max. Torque 40 daNm [3540 lb-in]

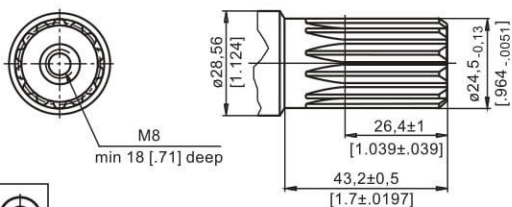

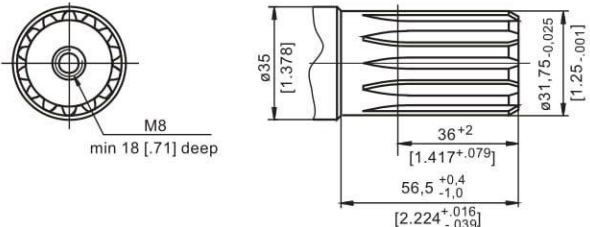

HB - $\varnothing 1 1/4"$ splined 14T, ANSI B92.1-1976 Norm
Max. Torque 77 daNm [6815 lb-in]

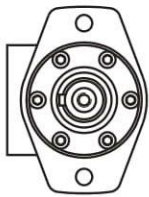

PERMISSIBLE SHAFT LOADS FOR MP AND MR MOTORS

The permissible radial shaft load P_{rad} depends on the speed n , RPM, distance L from the point of load to the mounting flange and shaft version.

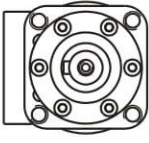
Mounting Flange			
Shaft Version	cylindrical - C, CO tapered - K, splined - SH	splined - HB cylindrical - CB	cylindrical - C, CO
Radial Shaft Load P_{rad} , in mm	$\frac{800}{n} \times \frac{25000}{95+L}$, daN*	$\frac{800}{n} \times \frac{18750}{95+L}$, daN*	$\frac{800}{n} \times \frac{25000}{101+L}$, daN*
Radial Shaft Load P_{rad} , in inch	$\frac{800}{RPM} \times \frac{2215}{3.74+L}$, lbs*	$\frac{800}{RPM} \times \frac{1660}{3.74+L}$, lbs*	$\frac{800}{RPM} \times \frac{2215}{3.98+L}$, lbs*

* $n < 200$ RPM; max P_{rad} =800 daN [1800 lbs]
 $n \geq 200$ RPM; $L < 55$ mm [2.2 in]

MP AND MR

Radial Shaft Load P_{rad} for C, CO Shaft Extensions by $L=30$ mm [1.18 in] (24 mm [.94 in])

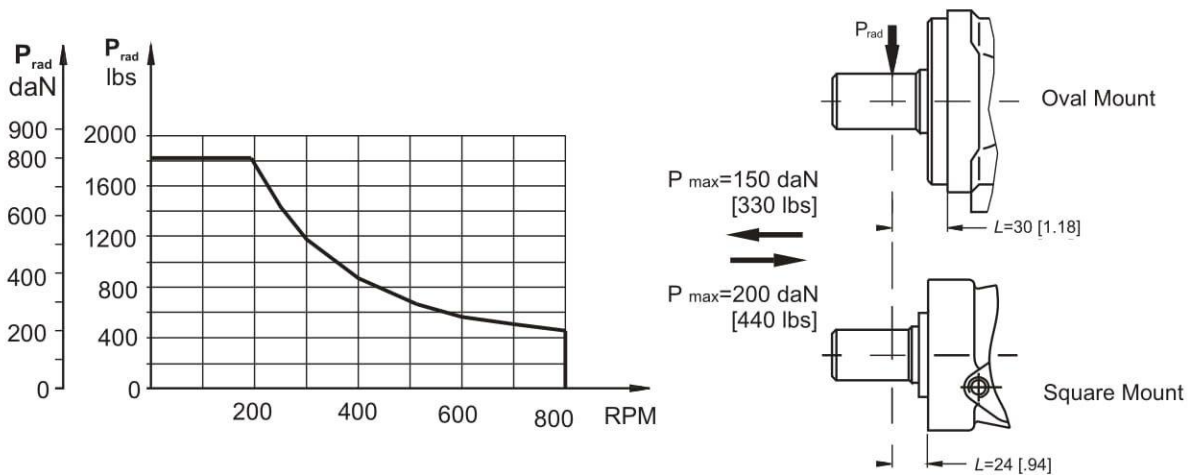

MPN AND MRN

The curves apply to a B10 bearing life of 2000 hours.

