

PC-2 POMPE A ENGRENAGES **GR. 2** STANDARD EUROPEEN CENTRAGE $\varnothing 36,5$ ARBRE CONIQUE 1:8
 GEAR PUMP STANDARD EUROPEAN $\varnothing 36,5$ FLANGE 1:8 TAPER SHAFT
 BOMBA DE ENGRANAJES BRIDA ESTANDAR EUROPEA $\varnothing 36,5$ EJE CONICO 1:8

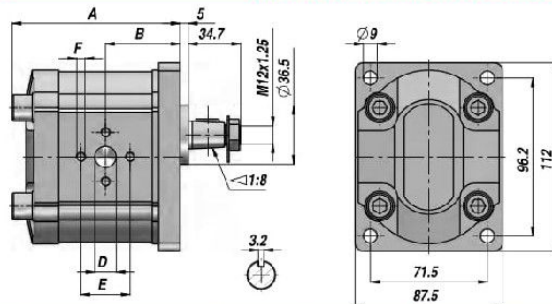
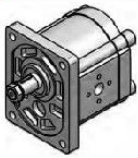

Code Code Código	Type Type Tipo	cm ³ /tr cm ³ /rev cm ³ /giro	P MAX bar		tr/min rpm - giro/min		A	B	IN D x E x F	OUT D x E x F	kg
			P1	P3	MAX	MIN					
PC*203EAA1G	PC*203	3,00	270	300	4000	800	91,1	43,6	$\varnothing 13 \times 30 \times M6$	$\varnothing 13 \times 30 \times M6$	3,50
PC*204EAA1G	PC*204	4,00	270	300	4000	600	92,7	44,4	$\varnothing 13 \times 30 \times M6$	$\varnothing 13 \times 30 \times M6$	3,50
PC*206EAA1G	PC*206	6,00	270	300	4000	600	96,0	46,0	$\varnothing 13 \times 30 \times M6$	$\varnothing 13 \times 30 \times M6$	3,50
PC*208EAA1G	PC*208	8,00	270	300	3500	500	99,3	47,7	$\varnothing 13 \times 30 \times M6$	$\varnothing 13 \times 30 \times M6$	3,50
PC*210EAA1G	PC*210	10,00	270	300	3000	500	102,6	49,3	$\varnothing 20 \times 40 \times M8$	$\varnothing 13 \times 30 \times M6$	4,00
PC*212EAA1G	PC*212	12,00	270	300	3000	500	105,9	51,0	$\varnothing 20 \times 40 \times M8$	$\varnothing 13 \times 30 \times M6$	4,00
PC*214EAA1G	PC*214	14,00	250	280	4000	500	109,3	52,7	$\varnothing 20 \times 40 \times M8$	$\varnothing 13 \times 30 \times M6$	4,00
PC*216EAA1G	PC*216	16,00	250	280	4000	500	112,7	54,4	$\varnothing 20 \times 40 \times M8$	$\varnothing 13 \times 30 \times M6$	4,00
PC*218EAA1G	PC*218	18,00	250	280	3600	400	116,0	56,0	$\varnothing 20 \times 40 \times M8$	$\varnothing 13 \times 30 \times M6$	4,00
PC*220EAA1G	PC*220	20,00	220	250	3200	400	119,3	57,7	$\varnothing 20 \times 40 \times M8$	$\varnothing 13 \times 30 \times M6$	4,00
PC*222EAA1G	PC*222	22,00	220	250	3000	400	122,6	59,3	$\varnothing 20 \times 40 \times M8$	$\varnothing 13 \times 30 \times M6$	4,20
PC*225EAA1G	PC*225	25,00	200	230	3000	400	127,6	61,8	$\varnothing 22 \times 40 \times M8$	$\varnothing 13 \times 30 \times M6$	4,20
PC*228EAA1G	PC*228	28,00	180	200	2500	400	132,6	64,3	$\varnothing 22 \times 40 \times M8$	$\varnothing 13 \times 30 \times M6$	4,20
PC*230EAA1G	PC*230	30,00	160	180	2500	400	135,9	66,0	$\varnothing 22 \times 40 \times M8$	$\varnothing 13 \times 30 \times M6$	4,40

* S = ROTATION GAUCHE - ANTICLOCKWISE - ROTACION IZQUIERDA
 * D = ROTATION DROITE - CLOCKWISE - ROTACION DERECHA

P1 = PRESSION MAXI D'EXERCICE - MAX. WORKING PRESSURE - PRESSION MAX DE TRABAJO
 P3 = PRESSION MAXI DE PICO - MAX. PEAK PRESSURE - PRESSION MAX DE PICO

SUR DEMANDE: CORPS TARAUDE "BSP"

ON REQUEST: "BSP" THREADED HOUSING

BAJO PEDIDO: CUERPO ROSCADO "BSP"

TECHNICAL INFORMATION

Veillez suivre et utiliser strictement les indications données dans ce catalogue pour des performances optimales et une durée de vie plus longue de la pompe.

Please strictly follow assembly and use indications given in this catalogue for top performance and longer life of pump.

Notes d'installations

Avant de démarrer le système sur une base continue, nous suggérons d'adopter comme suit des précautions simples.

- Vérifier que le sens de rotation de la pompe est cohérent avec celui de l'arbre de transmission, s'assurer qu'il n'y a pas de réversion.
- Vérifier l'alignement correct de l'arbre de la pompe et de l'arbre du moteur, il est nécessaire que la connexion n'induit pas de charges axiales ou radiales.
- Vérifier si la zone de contact entre la bague d'étanchéité et l'arbre est propre, enlevez toute la saleté, les copeaux et tous les corps étrangers des brides reliant les orifices d'entrée et de refoulement, la poussière pourrait provoquer une usure et des fuites plus rapides.
- S'assurer que les extrémités des tuyaux d'admission et de retour sont toujours au-dessous du niveau du liquide et aussi éloignés l'un de l'autre que possible.
- Remplir la pompe de fluide et tournez-la à la main.
- Débrancher le drain de la pompe au démarrage pour purger l'air du circuit.
- Toujours éviter ou limiter le démarrage de la pompe pour prolonger sa durée de vie.

INSTALLATION NOTES

Before starting the system on a continuous basis, we suggest to adopt as follows simple precautions.

- Check for the direction of rotation of the pump to be consistent with the drive shaft one, be sure no reversion revolved.
- Check for the proper alignment of pump shaft and motor shaft, it is necessary that the connection does not induce axial or radial loads.
- Check if contact area between seal ring and shaft is clean, remove all dirt, chips and all foreign bodies from flanges connecting inlet and delivery ports, dust could provoke quicker wear and leakage.
- Ensure that intake and return pipes ends are always below fluid level and as far from each other as possible.
- Fill the pump with fluid, and turn it by hand.
- Disconnect pump drain during startup to bleed air off the circuit.
- Always avoid or limit load starting for pump longer life.

Fluides hydrauliques

Utiliser des fluides hydrauliques spécifiques à base d'huile minérale ayant de bonnes propriétés antioxydantes, antimousses (désaération rapide), anti-usure, anti-corrosion et lubrifiante. Les fluides doivent également être conformes aux normes DIN51525 et VDMA24317 et passer au 11ème stade du test FZG.

Pour les modèles standards, la température du fluide doit être comprise entre -10 °C et 80 °C.

Les plages de cinématiques de viscosité des fluides sont les suivantes

HYDRAULIC FLUIDS

Use specific mineral oil based hydraulic fluids having good antioxidant, anti-foaming (rapid de-aeration), anti-wear, anti-corrosion and lubricating properties, Fluids should also comply with DIN 51525 and VDMA 24317 standards and get through 11th stage of FZG test.

For the standard models, the temperature of the fluid should range between -10 °C and +80 °C.

Fluid kinematic viscosity ranges are the following:

plage autorisée	allowed range	6...500 cSt
plage recommandée	recommended range	10...100 cSt
valeur autorisée au démarrage	value allowed at startup	...2000 cSt

Pression d'entrée

Dans des conditions de travail standard, la pression du tuyau d'admission est inférieure à la pression atmosphérique. La pression d'entrée de fonctionnement doit être comprise entre 0,7 et 3 bars (absolu).

INLET PRESSURE

Under standard working conditions, intake pipe pressure is lower than atmospheric pressure. The operating inlet pressure should range between 0.7 and 3 bars (absolute).

Recommandation de filtration

Il est largement connu que la plupart des défaillances précoces des pompes sont dues à des fluides contaminés. Comme une garantie ne peut pas être délivrée pour l'usure liée à la saleté, nous recommandons d'utiliser un filtre qui peut réduire le degré de contamination à une dimension admissible en termes de taille et de concentration des particules de saleté. Le système de filtrage doit toujours s'assurer que les niveaux de contamination ne dépassent pas les valeurs indiquées ci-dessous :

Pressure	<140 bar	140...210 bar	>210 bar
NAS 1638 Class	10	9	8
ISO 4406 Class	19/16	18/15	17/14
Ratio $\beta_x = 75$	25-40 m μ	12-15 m μ	6-12 m μ

FILTER RECOMMENDATION

It is widely known that most pumps early failures are due to contaminated fluids. As a warranty cannot be issued for dirt-related wear, we recommend a filter to be used, which can reduce the degree of contamination to a permissible dimension in terms of the size and concentration of dirt particles. The filtering system shall always ensure contamination levels not exceeding the values indicated below:

PRESSURE DEFINITION

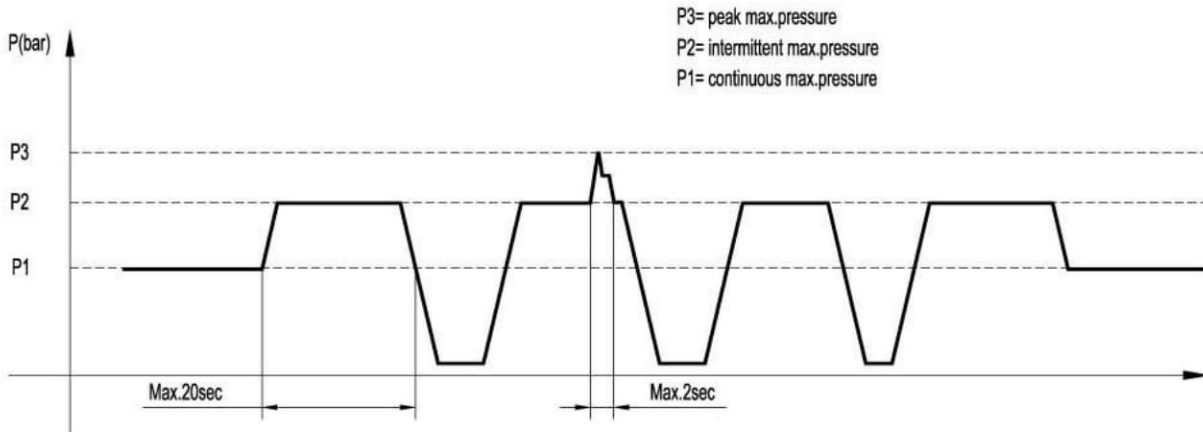

Lignes d'entrée et de refoulement

Les tuyaux du système hydraulique ne doivent pas montrer de changements brusques de direction, d'extrémités angulaires et de brusques différences de section.

Ils ne devraient pas être trop longs ou hors de proportion.

La section transversale du tuyau doit être dimensionnée de sorte que la vitesse du fluide ne dépasse pas les valeurs recommandées.

Il est conseillé d'examiner attentivement la réduction de diamètre possible des tuyaux d'entrées ou de sorties montés sur les raccords à bride.

les valeurs de références sont les suivantes:

INLET AND DELIVERY LINES

Hydraulic system pipes should show no sudden changes of direction, sharp bends and sudden differences in cross-section.

They should not be too long or out of proportion.

Pipe cross-section should be sized so that fluid velocity does not exceed recommended values.

It is advisable to carefully consider the possible diameter reduction of the inlet or outlet pipes fitted on flange fittings.

Reference values are the following:

Intake line	0.5...1.6 m/s
Delivery line	2...6 m/s
Return line	1.6...3 m/s

Sens de rotation

Définition du sens de rotation : en se plaçant devant la pompe avec l'arbre menant positionné en haut vers l'observateur, la pompe tourne dans le sens des aiguilles d'une montre en cas de rotation à droite "D". Le contraire se produira avec les pompes "S" gauches, gardant le même point de vue.

ROTATION DIRECTION

Definition of rotation direction: when standing before the pump with driving shaft up with its projecting end towards the observer, the pump is rotating clockwise in case of right-hand rotation "D". The contrary will happen with left-hand pumps "S", keeping the same point of view.

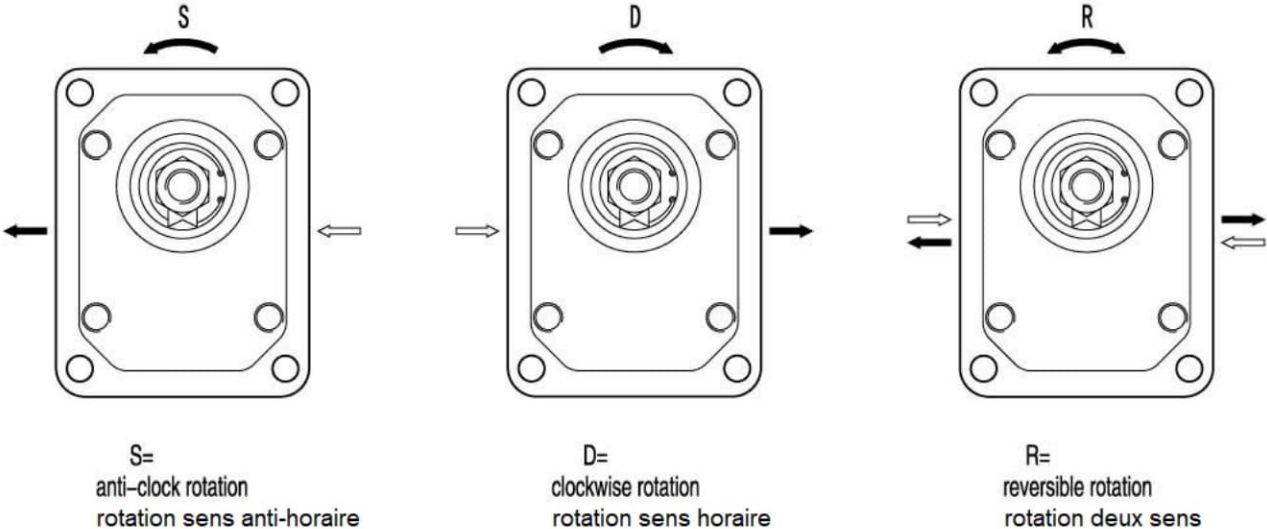

Calculs de conceptions pour pompe

DESIGN CALCULATIONS FOR PUMP

Flow	Q	L/min
Torque	M	Nm
Power	P	kW
Speed	n	r/min
Pressure	ΔP	bar
Displacement	V	cm ³ /rev

Volumetric efficiency	$\eta_v = \eta_v(V, \Delta P, n)$	≈0.93
Mechanical efficiency	$\eta_{hm} = \eta_{hm}(V, \Delta P, n)$	≈0.85
Total efficiency	$\eta_t = \eta_v \cdot \eta_{hm}$	≈0.80

$Q = V \cdot n \cdot \eta_v \cdot 10^{-3}$	[L/min]
$M = (\Delta P \cdot V) / (62.83 \cdot \eta_{hm})$	[Nm]
$P = (\Delta P \cdot Q) / (612 \cdot \eta_t)$	[kW]

BHP2B0

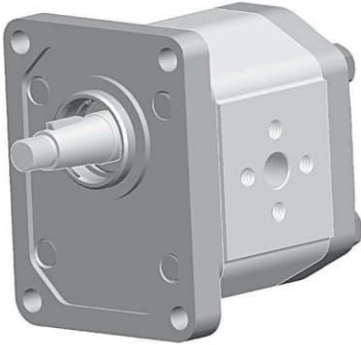

M6 thread depth 13, M8 thread depth 17.
 To mount the pump, n.4 M10 screws,
 with a torque wrench setting fixed
 at 70...75 Nm.
 Shaft M12x1.25 nut, with a torque
 wrench setting fixed at 50 Nm.

OUTLET

INLET

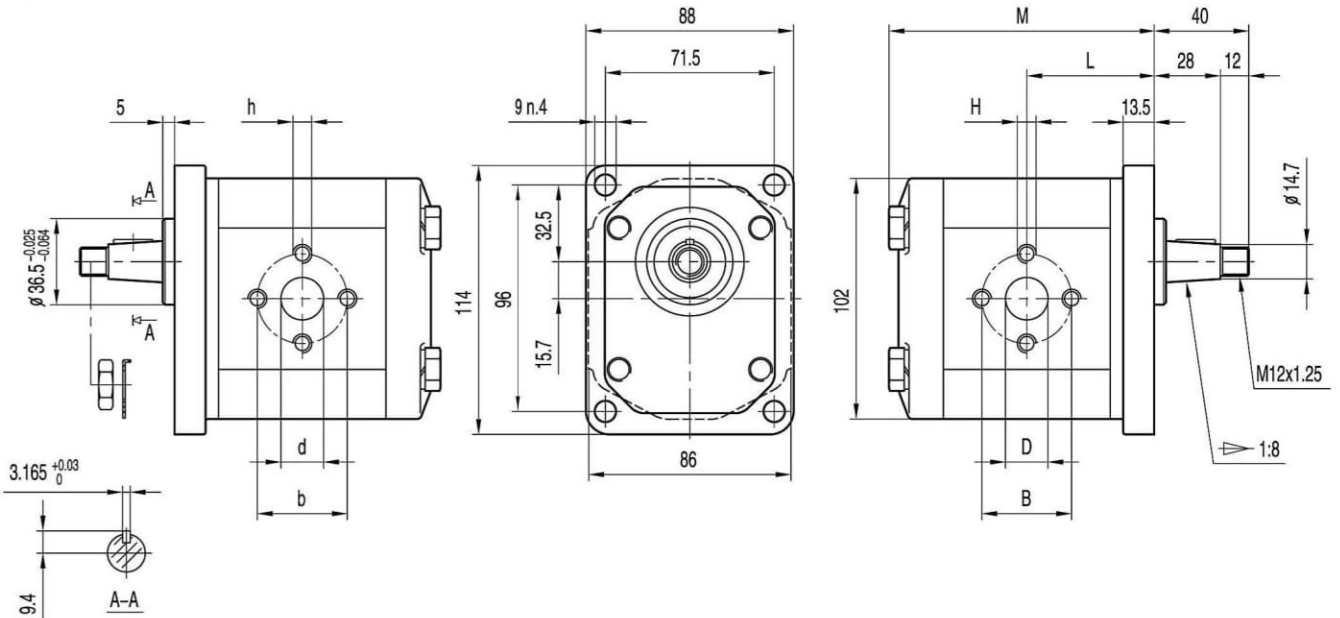

Type	Displacement (cm ³ /rev)	Max pressure			Max. speed (r/min)	Min. speed (r/min)	Dimensions							
		P1 bar	P2 bar	P3 bar			M mm	L mm	B mm	D mm	H mm	b mm	d mm	h
BHP2B0-D-3	3	270	285	300	4000	800	91.1	43.6	30	13	M6	30	13	M6
BHP2B0-D-4	4	270	285	300	4000	600	92.7	44.4	30	13	M6	30	13	M6
BHP2B0-D-6	6	270	285	300	4000	600	96	46	30	13	M6	30	13	M6
BHP2B0-D-8	8	270	285	300	3500	500	99.3	47.7	30	13	M6	30	13	M6
BHP2B0-D-10	10	270	285	300	3000	500	102.6	49.3	40	20	M8	30	13	M6
BHP2B0-D-12	12	270	285	300	3000	500	105.9	51	40	20	M8	30	13	M6
BHP2B0-D-14	14	250	265	280	4000	500	109.3	52.7	40	20	M8	30	13	M6
BHP2B0-D-16	16	250	265	280	4000	500	112.7	54.4	40	20	M8	30	13	M6
BHP2B0-D-18	18	250	265	280	3600	400	116	56	40	20	M8	30	13	M6
BHP2B0-D-20	20	220	235	250	3200	400	119.3	57.7	40	20	M8	30	13	M6
BHP2B0-D-22	22	220	235	250	3000	400	122.6	59.3	40	20	M8	30	13	M6
BHP2B0-D-25	25	200	215	230	3000	400	127.6	61.8	40	22	M8	30	13	M6
BHP2B0-D-28	28	180	190	200	2500	400	132.6	64.3	40	22	M8	30	13	M6
BHP2B0-D-30	30	160	170	180	2500	400	135.9	66	40	22	M8	30	13	M6

BAP2[BHP2]

FRONT COVER

SHAFTS

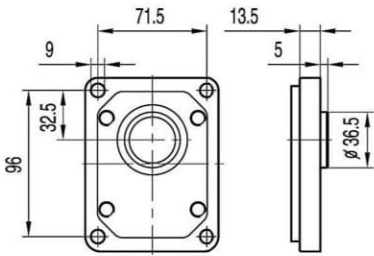

B0

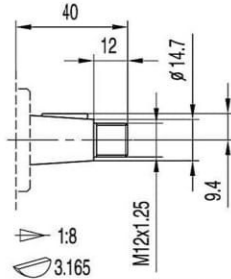

T0

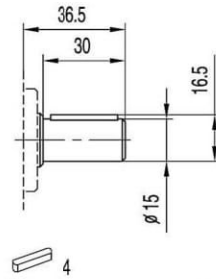

C4

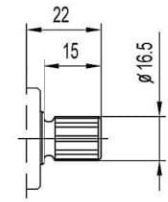

S7

DIN5482 B17X14

Max.Torque 200 Nm

Max.Torque 135 Nm

Max.Torque 150 Nm

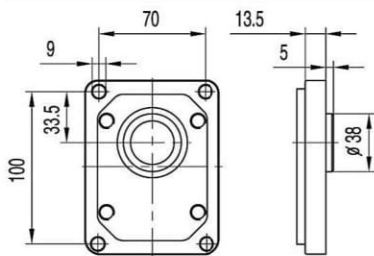

B1

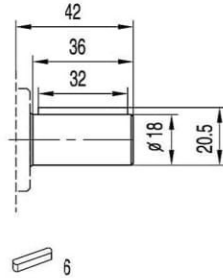

C2

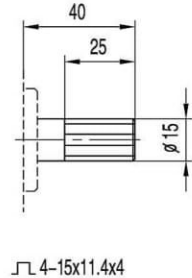

H0

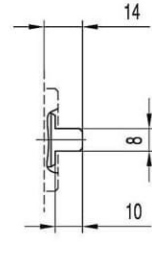

G0

4-15x11.4x4

Max.Torque 150 Nm

Max.Torque 185 Nm

Max.Torque 100 Nm

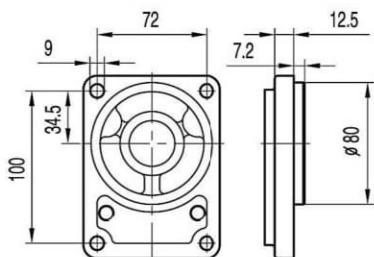

B2

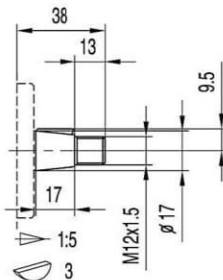

T1

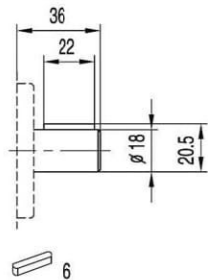

C3

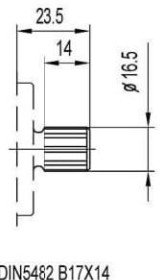

S6

DIN5482 B17X14

Max.Torque 180 Nm

Max.Torque 150 Nm

Max.Torque 150 Nm

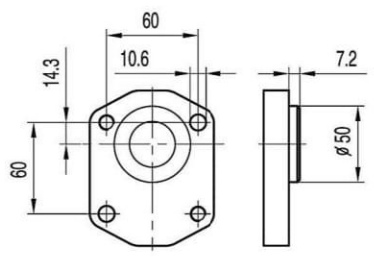

Q0

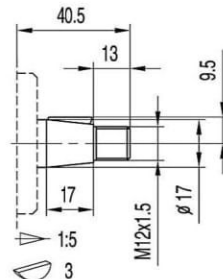

T1

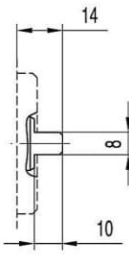

G0

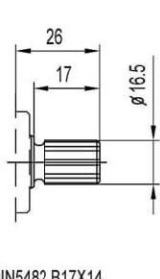

S3

DIN5482 B17X14

Max.Torque 180 Nm

Max.Torque 100 Nm

Max.Torque 150 Nm

BAP2[BHP2]

FRONT COVER

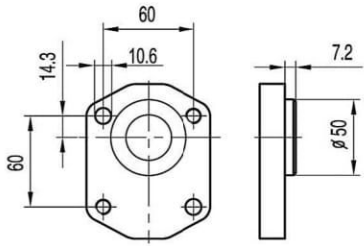

Q1

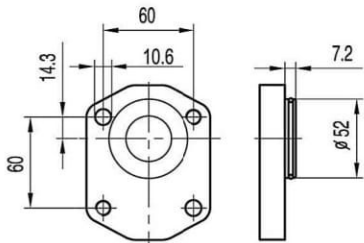

Q2

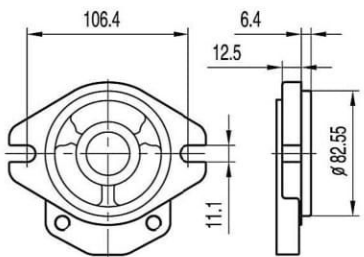

A0

SHAFTS

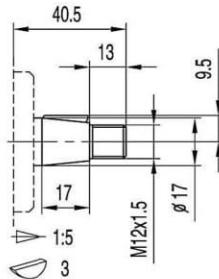

T1

Max.Torque 180 Nm

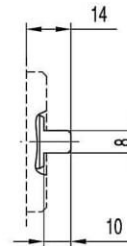

G0

Max.Torque 100 Nm

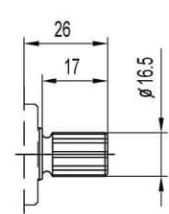

DIN5482 B17X14

S3

Max.Torque 150 Nm

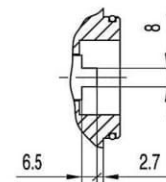

G1

Max.Torque 100 Nm

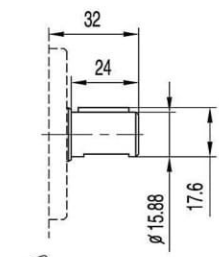

C0

Max.Torque 140 Nm

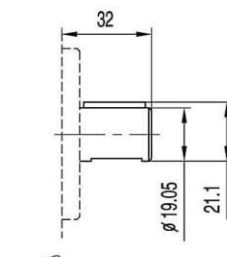

C1

Max.Torque 160 Nm

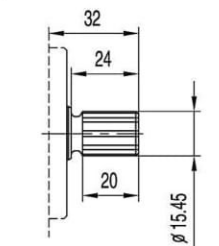

DP16/32-30° -9T

S0

Max.Torque 185 Nm

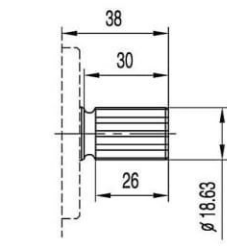

DP16/32-30° -11T

S1

Max.Torque 200 Nm

BAP2[BHP2]

PORTS

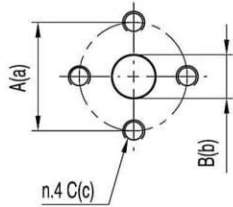

E0/E1/E2

TYPE	PORTS CODE	INLET			OUTLET		
		A	B	C	a	b	c
BA(H)P2...3 ÷ BA(H)P2...8	E0	30	13	M6	30	13	M6
BA(H)P2...10 ÷ BA(H)P2...22	E1	40	20	M8	30	13	M6
BA(H)P2...25 ÷ BA(H)P2...30	E2	40	22	M6	30	13	M6

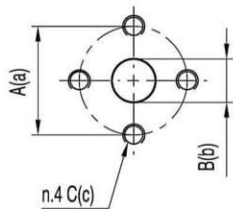

E3

TYPE	INLET			OUTLET		
	A	B	C	a	b	c
BA(H)P2...3 ÷ BA(H)P2...8	38	14	M8	38	10	M8
BA(H)P2...10 ÷ BA(H)P2...22	38	18	M8	38	15	M8
BA(H)P2...25 ÷ BA(H)P2...30	38	20	M8	38	15	M8

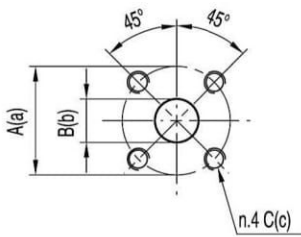

F0/F1

TYPE	PORTS CODE	INLET			OUTLET		
		A	B	C	a	b	c
BA(H)P2...3 ÷ BA(H)P2...8	F0	40	15	M6	35	15	M6
BA(H)P2...10 ÷ BA(H)P2...30	F1	40	20	M6	35	15	M6

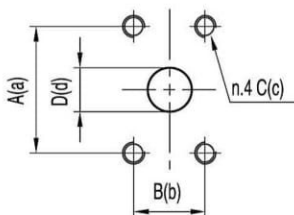

F2/F3/F4

TYPE	PORTS CODE	INLET				OUTLET			
		A	B	C	D	a	b	c	d
BA(H)P2...3 ÷ BA(H)P2...16	F2	38.1	17.48	5/16-18UNC	13	38.1	17.48	5/16-18UNC	13
BA(H)P2...18 ÷ BA(H)P2...20	F3	47.63	22.23	3/8-16UNC	20	38.1	17.48	5/16-18UNC	13
BA(H)P2...22 ÷ BA(H)P2...30	F4	47.63	22.23	3/8-16UNC	20	47.63	22.23	3/8-16UNC	20

BAP2[BHP2]

PORTS

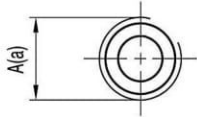

L0/L1

TYPE	PORTS CODE	INLET	OUTLET
		A	a
BA(H)P2...3 ÷ BA(H)P2...6	L0	G1/2	G1/2
BA(H)P2...8 ÷ BA(H)P2...30	L1	G3/4	G1/2

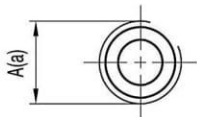

R0/R1/R2

TYPE	PORTS CODE	INLET	OUTLET
		A	a
BA(H)P2...3 ÷ BA(H)P2...12	R0	PT1/2	PT1/2
BA(H)P2...14 ÷ BA(H)P2...25	R1	PT3/4	PT1/2
BA(H)P2...28 ÷ BA(H)P2...30	R2	PT 1	PT3/4

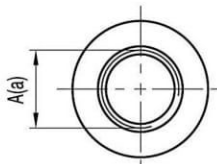

U0/U1

TYPE	PORTS CODE	INLET	OUTLET
		A	a
BA(H)P2...3 ÷ BA(H)P2...28	U0	1 1/16-12 UNF	7/8-14 UNF
BA(H)P2...30	U1	1 5/16-12 UNF	7/8-14 UNF