

Code Code	Type Type	Arbre - Shaft		Rapport Ratio	kg
		Entrée - Input	Sortie - Output		
BM60001010	GBML32 - M - 1 / 1.5	Mâle Male 1"3/8 SAE J 1170	Femelle Female A 25x22 DIN 5482	1.5	5,30
BM60001020	GBML32 - M - 1 / 2.0			2.0	5,30
BM60001030	GBML32 - M - 1 / 2.5			2.5	5,30
BM60001040	GBML32 - M - 1 / 3.0			3.0	5,30
BM60001050	GBML32 - M - 1 / 3.5			3.5	5,30
BM60001060	GBML32 - M - 1 / 3.8			3.8	5,30
BM60002010	GBML32 - F - 1 / 1.5	Femelle Female 1"3/8 SAE J 1170	Femelle Female A 25x22 DIN 5482	1.5	4,50
BM60002020	GBML32 - F - 1 / 2.0			2.0	4,50
BM60002030	GBML32 - F - 1 / 2.5			2.5	4,50
BM60002040	GBML32 - F - 1 / 3.0			3.0	4,50
BM60002050	GBML32 - F - 1 / 3.5			3.5	4,50
BM60002060	GBML32 - F - 1 / 3.8			3.8	4,50
BM60004040	GBML32 - FR - 1 / 3.0	Femelle FR Female FR 1"3/8 SAE J 1170	Femelle Female A 25x22 DIN 5482	3.0	4,70
BM60004050	GBML32 - FR - 1 / 3.5			3.5	4,70
BM60004060	GBML32 - FR - 1 / 3.8			3.8	4,70

MATERIEL CORPS : ALUMINIUM
BODY MATERIAL : ALUMINIUM

• TAVOLA RICAMBI MOLTIPLICATORE Gr. 2
 • TABLEAU DES PIÈCES DÉTACHÉES POUR MULTIPLICATEUR Gr. 2
 • SPARE PARTS TABLE OVER-GEAR Gr. 2
 • ERSATZTEILLISTE ÜBERSETZUNGSGETRIEBE Gr. 2

SERIE: 60000

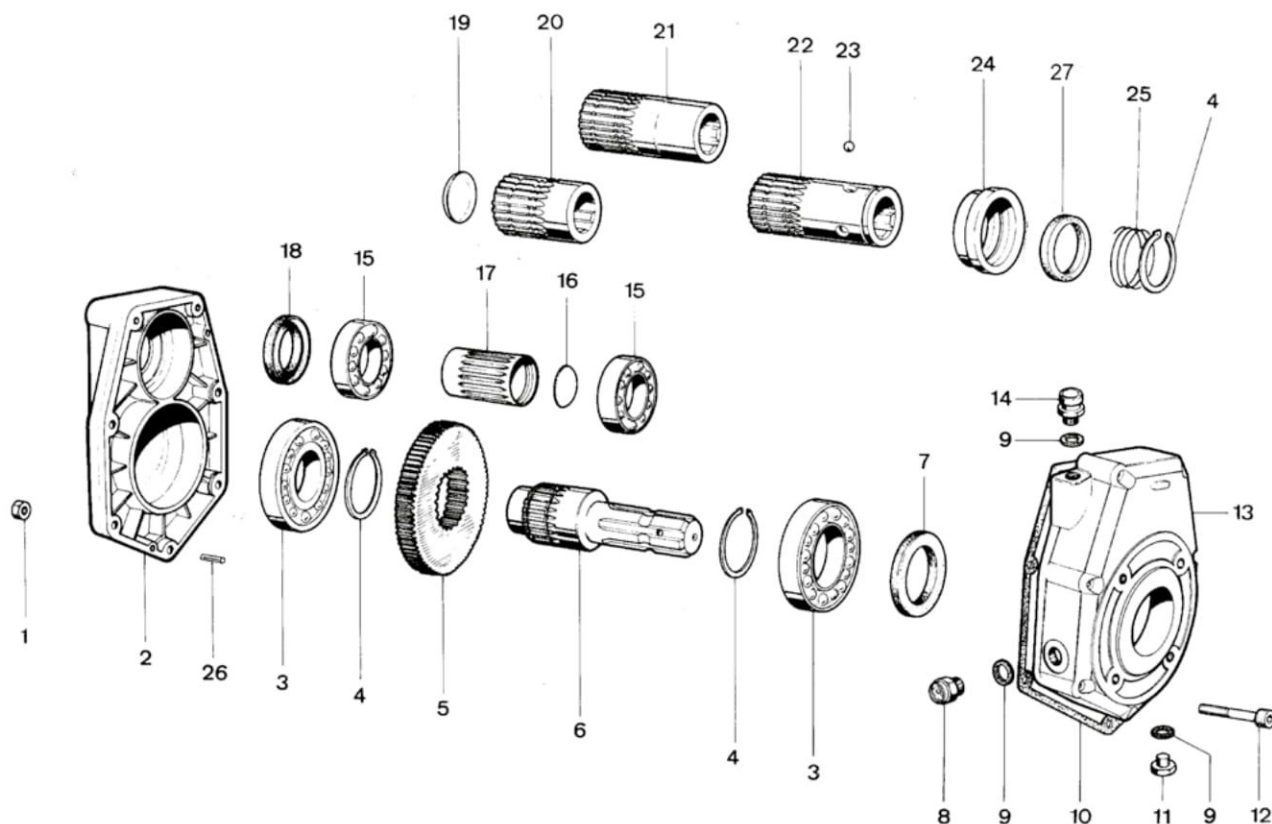

POS.	DENOMINAZIONE	DENOMINATION	DESCRIPTION	BEZEICHNUNG	Q.TÀ
1	Dado M6	Ecrou M6	Nut M6	Mutter M6	8
2	Coperchio	Couvercle	Cover	Dekel	1
3	Cuscinetto tipo 6010	Palier 6010	Bearing type 6010	Kugellager, Type 6010	2
4	Seeger Ø 50	Circlip Ø 50	Snap ring dia. 50	Seegerring, Durchm. 50	3
5	Corona	Couronne	Ring gear	Zahnkranz	1
6	Albero presa di forza maschio 1 3/8"	Arbre prise de force mâle 1" 3/8	Male P.T.O. shaft 1" 3/8	Antriebswelle mit Aussenverkeilung 1 3/8"	1
7	Anello di tenuta Ø 50x65x8	Bague d'étanchéité 50x65x8	Sealing ring Ø 50x65x8	Dichtring, Durchm. 50x65x8	1
8	Tappo livello olio 3/8"	Bouchon niveau huile 3/8"	Oil level plug 3/8"	Ölstandschaube 3/8"	1
9	Guarnizione	Joint	Gasket	Dichtung	3
10	Guarnizione	Joint	Gasket	Dichtung	1
11	Tappo scarico olio 3/8"	Bouchon vidange huile 3/8"	Oil drain plug 3/8"	Ölablaßschraube 3/8"	1
12	Vite T.C.E.I. M6x50	Vis T.C.H.C. M6x50	Socket capscrew M6x50	Zylinderkopfschraube mit Innensechskant M6x50	8
13	Scatola	Carcasse	Housing	Gehäuse	1
14	Tappo sfiato olio 3/8"	Bouchon reniflard huile 3/8"	Oil breather plug 3/8"	Entlüftungsschraube 3/8"	1
15	Cuscinetto tipo 6007	Palier 6007	Bearing type 6007	Kugellager, Type 6007	2
16	Coperchietto DIN 470 - Ø 27	Petit couvercle DIN 470 D. 27	Cap DIN 470 Ø 27	Deckel DIN 470, Durchm. 27	1
17	Pignone	Pignon	Pinion Gear	Ritzel	1
18	Anello di tenuta Ø 35x52x7	Bague étanchéité 35x52x7	Sealing ring Ø 35x52x7	Dichtring, Durchm. 35x52x7	1
19	Coperchietto DIN 470 - Ø 40	Petit couvercle DIN 470 D. 40	Cap DIN 470 Ø 40	Deckel DIN 470, Durchm. 40	1
20	Albero presa di forza femmina 1 3/8" corto	Arbre prise de force femelle 1" 3/8 court	Female P.T.O. shaft 1" 3/8 short	Antriebswelle mit Innenverkeilung 1 3/8", kurz	1
21	Albero presa di forza femmina 1 3/8" lungo	Arbre prise de force femelle 1" 3/8 long	Female P.T.O. shaft 1" 3/8 long	Antriebswelle mit Innenverkeilung 1 3/8", lang	1
22	Albero presa di forza femmina 1 3/8" attacco rapido	Arbre prise de force femelle 1" 3/8 attelage rapide	Female P.T.O. shaft 1" 3/8 quick fitting	Antriebswelle mit Innenverkeilung 1 3/8", mit Schnellkupplung	1
23	Sfera	Bille	Ball	Kugel.	3
24	Anello porta molla	Bague porte-ressort	Spring ring	Federhaltering	1
25	Molla	Ressort	Spring	Feder	1
26	Spina 5x16	Goupille 5x16	Peg 5x16	Stift, Durchm. 5x16	2
27	Anello	Bague	Ring	Ring	1

- **MOLTIPLICATORE POMPE Gr. 2**
- **MOLTIPLICATEUR POUR POMPES Gr. 2**
- **PUMP OVER-GEAR Gr. 2**
- **ÜBERSETZUNGSGETRIEBE FÜR PUMPEN Gr. 2**

SERIE: 60000

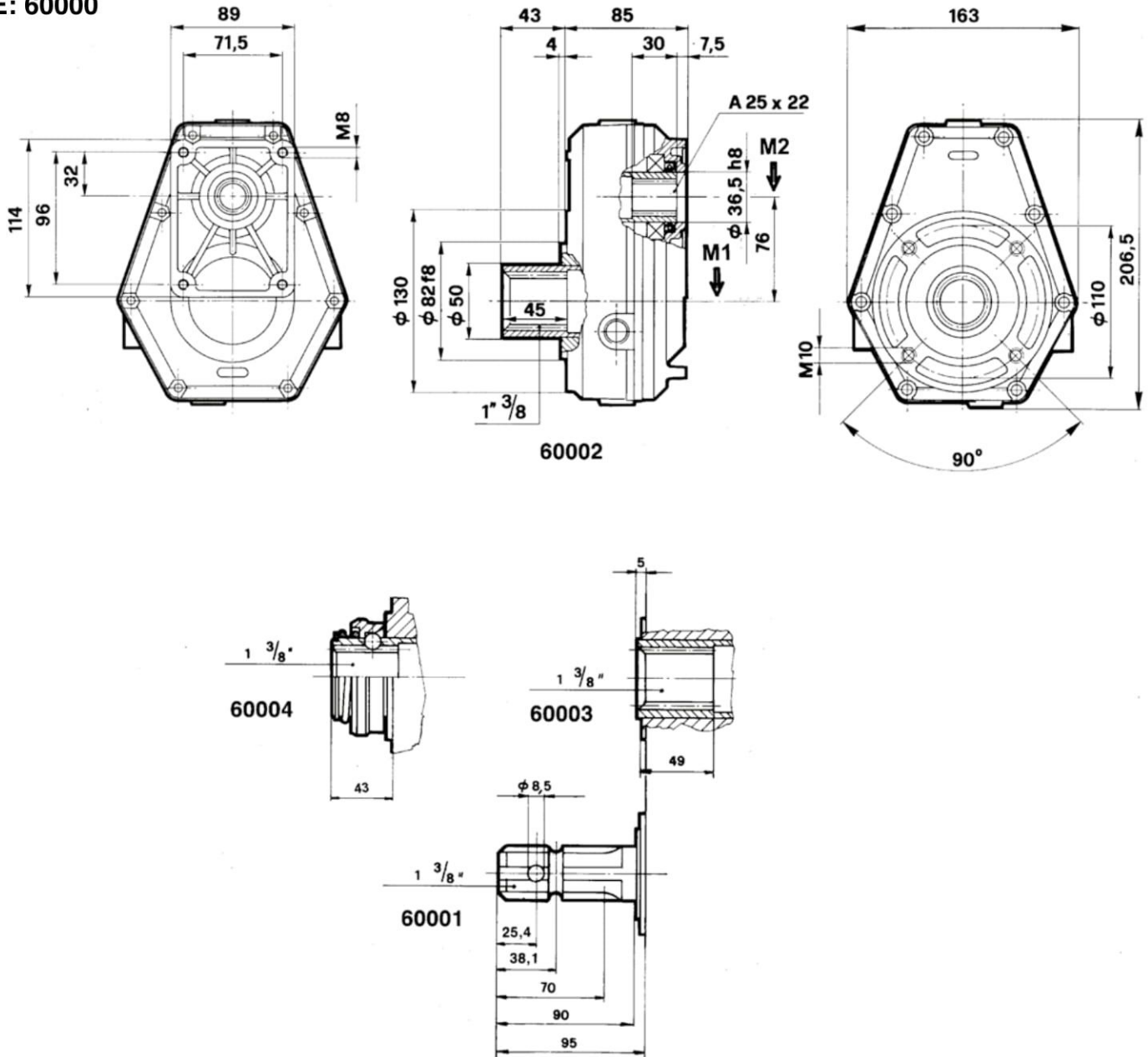

Livello max olio: it 0,220

M1 da Nm	M2 da Nm	N. 1 giri/1' tours/1' R.P.M U/min	N. 2 giri/1' tours/1' R.P.M U/min	I N.1/N.2	POTENZA Kw	G Kg
17,8	11,9	540	810	1,5	10	5,5
15,2	7,6	540	1080	2	10	5,5
16,5	6,6	540	1350	2,5	10	5,5
18	5,5	540	1680	3	10	5,5
18,6	5,8	540	1836	3,5	10	5,5
15,9	4,2	540	2052	3,8	10	5,5

- FLANGIE PER MOLTIPLICATORI SERIE: 60000
- FLANGE POUR MULTIPLICATEUR SERIES 60000
 - BRYDE FOR OVER-GEAR SERIE: 60000
- FLANSCH FÜR ÜBERSETZUNGSGETRIEBE SERIE: 60000

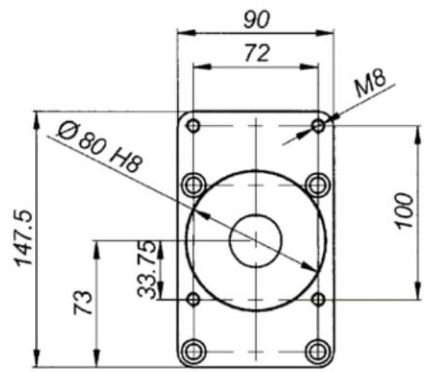

50100

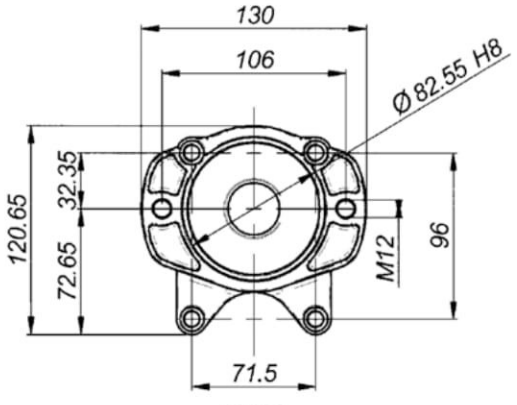

60100

	FLANGIA: TIPO, BRIDE: TYPE FLANGE: TYPE, FLANSCHTYPE	
	Gr. 2 BOSCH	SAE A Gr. 2
Code	50100	60100
G	8	12
H	13	32